

ACREASE

60" PRO FINISH CUT



OWNER'S MANUAL

With Assembly Instructions

For Model: Pro60V

KUNZ ENGINEERING, INC. / MENDOTA, IL 61342 / PH (815) 539-6954



SAFETY INTRODUCTION

Your safety, and the safety of others, is very important. To help you make informed decisions about safety, we have provided operating procedures and other information on labels and in this manual. This information alerts you to potential hazards that could hurt you or others.

You will find important safety information in a variety of forms, including:

Safety Labels – on the mower.

Safety Messages – preceded by a safety alert symbol  and one of three signal words: **DANGER**, **WARNING**, or **CAUTION**.

These signal words mean:



DANGER: Indicates an imminently hazardous situation that, if not avoided, will result in death or serious injury. This signal word is to be limited to the most extreme situations typically for machine components which, for functional purposes, cannot be guarded.



WARNING: Indicates a potentially hazardous situation that, if not avoided, could result in death or serious injury, and includes hazards that are exposed when guards are removed. It may also be used to alert against unsafe practices.



CAUTION: Indicates a potentially hazardous situation that, if not avoided, may result in minor or moderate injury. It may also be used to alert against unsafe practices.

This entire manual is filled with important safety information. Please read it carefully.

IMPORTANT SAFETY INFORMATION



WARNING: Do not allow anyone to operate this equipment who has not fully read and comprehended the safety manual and who has not been properly trained in the safe operation of the equipment.



WARNING: Operator should be familiar with all functions of the unit.



DANGER: Keep hands, feet, hair and clothing away from moving parts.



WARNING: Remove all objects from the work area that might be picked up and thrown by the blades.



WARNING: Do not mow when children and others are around.



WARNING: Keep all safety shields and deflectors in place during operation.



WARNING: Shut off the engine and allow the mower blades to come to a complete stop before making any adjustments to the mower.



WARNING: Shut off engine before disconnecting the wing mower from the tow vehicle or attempting to move the wing mower by hand.



WARNING: Never carry children or passengers.



WARNING: Do not allow children to operate this machine.

This entire manual is filled with important safety information. Please read it carefully.

SAFETY SIGNS AND LOCATIONS

WARNING

AVOID INJURY OR DEATH

- Read and follow owner's manual.
- Know location and function of all controls.
- Before starting engine, remove grass build-up from under safety shields.
- Before starting engine, attach machine to tow vehicle.
- Shut off engine before disconnecting machine from tow vehicle or attempting to move machine by hand.
- Do not fill fuel tank while engine is running or hot.
- If tow vehicle stops going forward, stop engine on towed mower before trying to push or pull tow vehicle.
- When making turns, slow down and watch ends of towed mower.
- Never carry children or passengers.
- Look down, to the sides, and behind before and while backing.
- Do not allow children to operate this machine.
- Do not mow when children and others are around.
- Remove all objects that may be thrown by blade.
- Keep safety shields and deflectors in place.
- Shut off engine while in transport.
- Before dismounting tow vehicle: shift to neutral, disengage power to tow vehicle mower, and set parking brake.
- Be sure blades, engine and moving parts are stopped before placing hands or feet near blade or performing service.



275003 –
Danger Decal,
Cut Hand & Foot



275007 –
Warning Decal,
Belt Shield

275002 – Warning Decal,
General

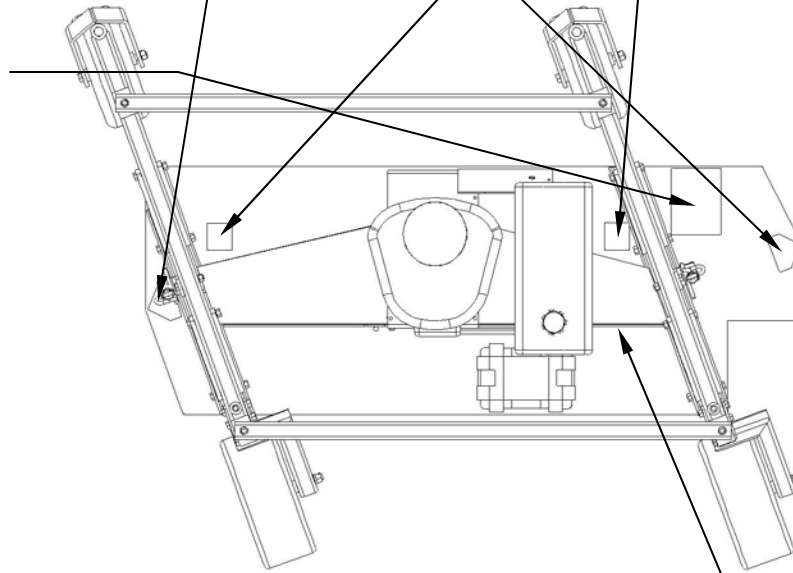

Serial # & Model # Decal



Clean or Replace Any Safety Signs That Are not Readable or Damaged

Replacement decals can be purchased from your local dealer or

Kunz Engineering Inc.
Mendota, IL 61342
(815) 539-6954
www.kunzeng.com

ASSEMBLY INSTRUCTIONS

READ THE COMPLETE ASSEMBLY INSTRUCTIONS BEFORE STARTING THE ASSEMBLY.

You should have:

- one mower deck assembly
- two carrier arm assemblies
- two cross brace tubes
- one tongue assembly (Lawn & Garden Hitching or ATV Tongue)
- one tow vehicle hitch assembly (only included on Lawn & Garden Hitching)

Optional hitches:

- one tongue extension
- one rear hitch assembly

A. ASSEMBLY OF MOWER WHEELS

1. Set the mower deck assembly on wood blocks so that it is suspended off the ground.

Note: The operator controls are on the front of the deck. (Left and right are determined by looking in the direction of travel or by standing at the rear of the deck assembly looking forward.)

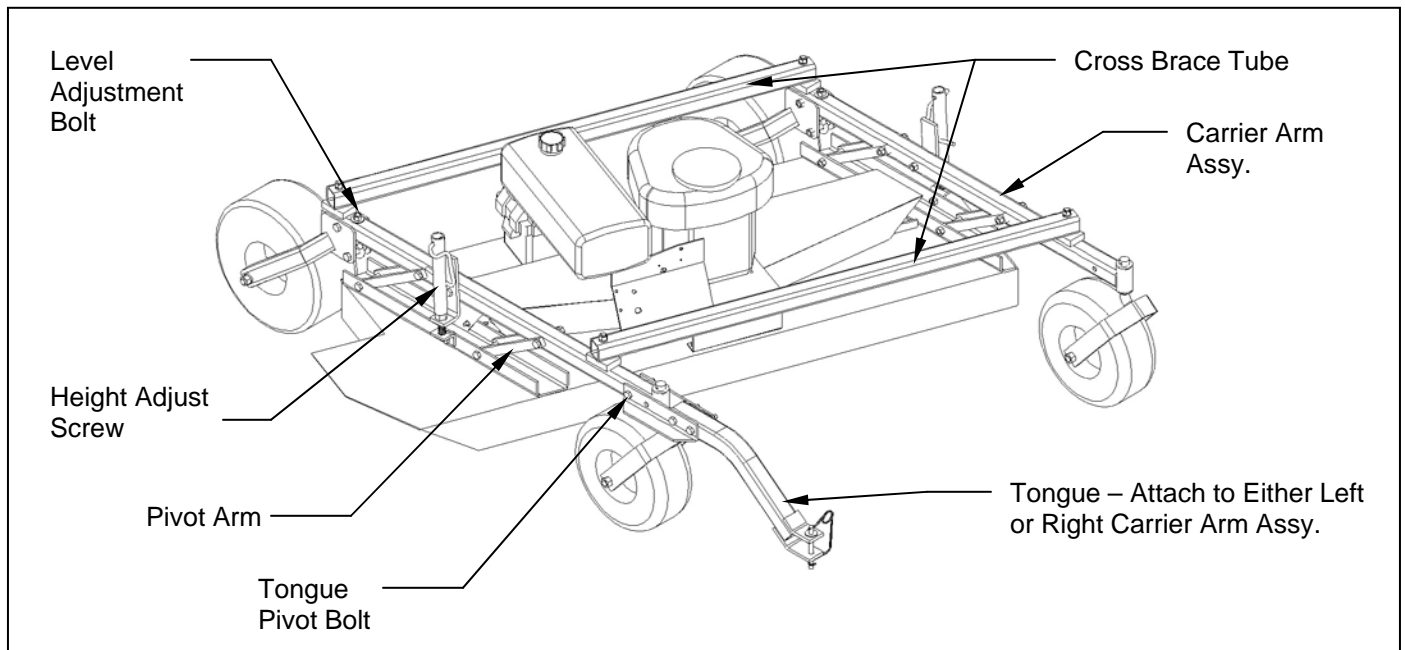

Figure 1. Assembly of Carrier Arm Assy., Tongue and Cross Brace Tubes

2. Install the two carrier arm assemblies in the pivot arms, which are located on the mower deck assembly. Place the assembly so that the castored tires are on the front and the fixed tires are on the back. **See figure 1.** Secure with 1/2" x 3-1/2" hex head bolts and lock nuts provided on

the pivot arms. Mount the height adjust screw on the deck assembly in the hole provided. Secure with the 1/2"x1" hex head bolt and lock nut provided on the height adjust screw.

Note: Tighten 1/2" x 3-1/2" and 1/2" x 1" hex head bolts until just snug. This area needs to pivot when adjusting the height. Under tightening can result in excessive wear and flexing. Over tightening will make adjusting the cutting height very difficult.

3. Remove the 1/2" x 5-1/2" bolts and lock nuts from the ends of both of the cross brace tubes. Attach the cross brace tubes to the two remaining unused holes located on the top of each carrier arm. Place the 1/2" x 5-1/2" bolts through the carrier arm from the bottom up. Place the lock nut on the bolt from the top side. Snug the lock nut up but do not fully tighten. The cross brace tube needs to pivot slightly during height adjustment.

B. INSTALLATION OF LAWN & GARDEN HITCHING (refer to the Operation and Adjustment Section for recommended hitching)(if the ATV Tongue was purchased refer to section C. Installation of ATV Tongue)

1. The tongue can be installed either on the left or right caster assembly depending on how the wing mower will be towed. **See figure 1.** Tighten the lock nut on the 1/2" x 3-1/2" pivot bolt so the tongue is free to pivot but does not move sideways.

Note: The tongue can be installed upside down so it will match up with tow vehicles with higher hitches.

2. The tow vehicle hitch provided is a universal hitch that should fit most tow vehicles. Slight modifications may be necessary for some tow vehicles.
3. Attach the tow vehicle hitch to the tow vehicle draw bar top or bottom depending on best support, and secure with the longer 1/2" hex head bolt, flatwasher, nut, and lockwasher provided. **See figure 2.**

Note: On some tow vehicles the draw bar will need to be strengthened to support the hitch assembly securely.

4. Adjust the hitch stop angle with stop bolts as close as possible to the vertical member on the back of the tow vehicle and adjust stop bolts securely against vertical member to keep hitch from pivoting from side to side.

Note: The hitch should be positioned on the tow vehicle so the stop bolts have a solid member to adjust to. On most tow vehicles two bolts can be used to attach the hitch assembly to the draw bar, eliminating the need for the hitch stop angle.

5. The telescoping hitch can either be installed to the left or right and should clear the back of the tire by about 2".
6. If one mower is pulled on both the left and right side of the tow vehicle, then one telescoping hitch can be mounted to the left and one to the right.

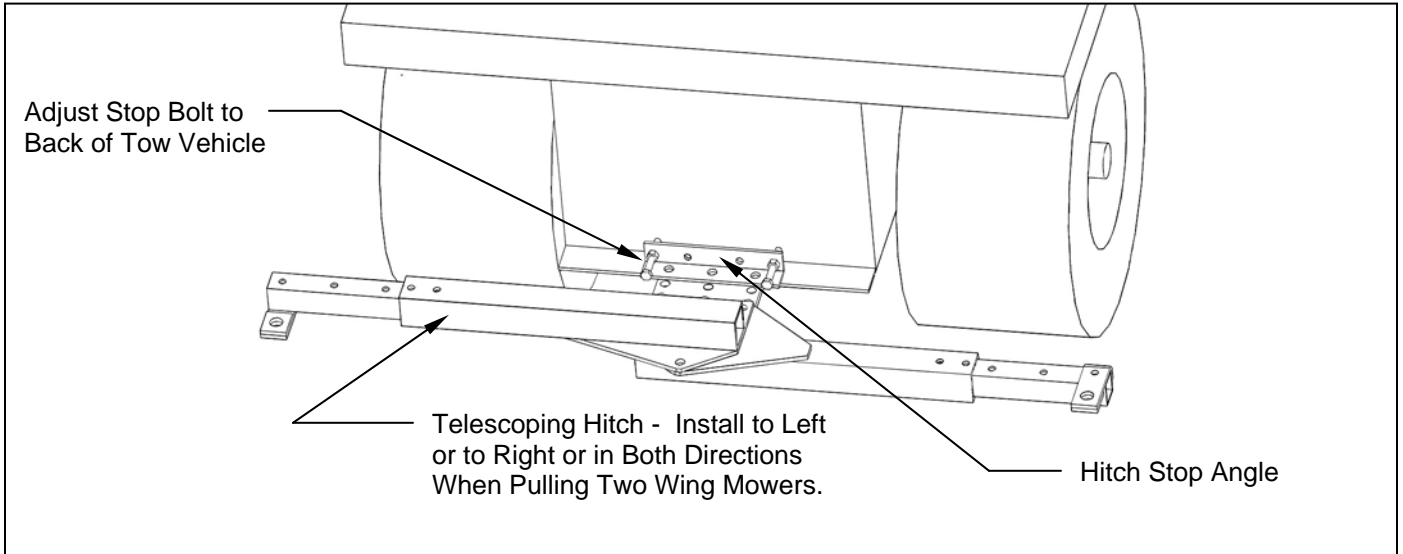

Figure 2: Installation of Tow Vehicle Hitch

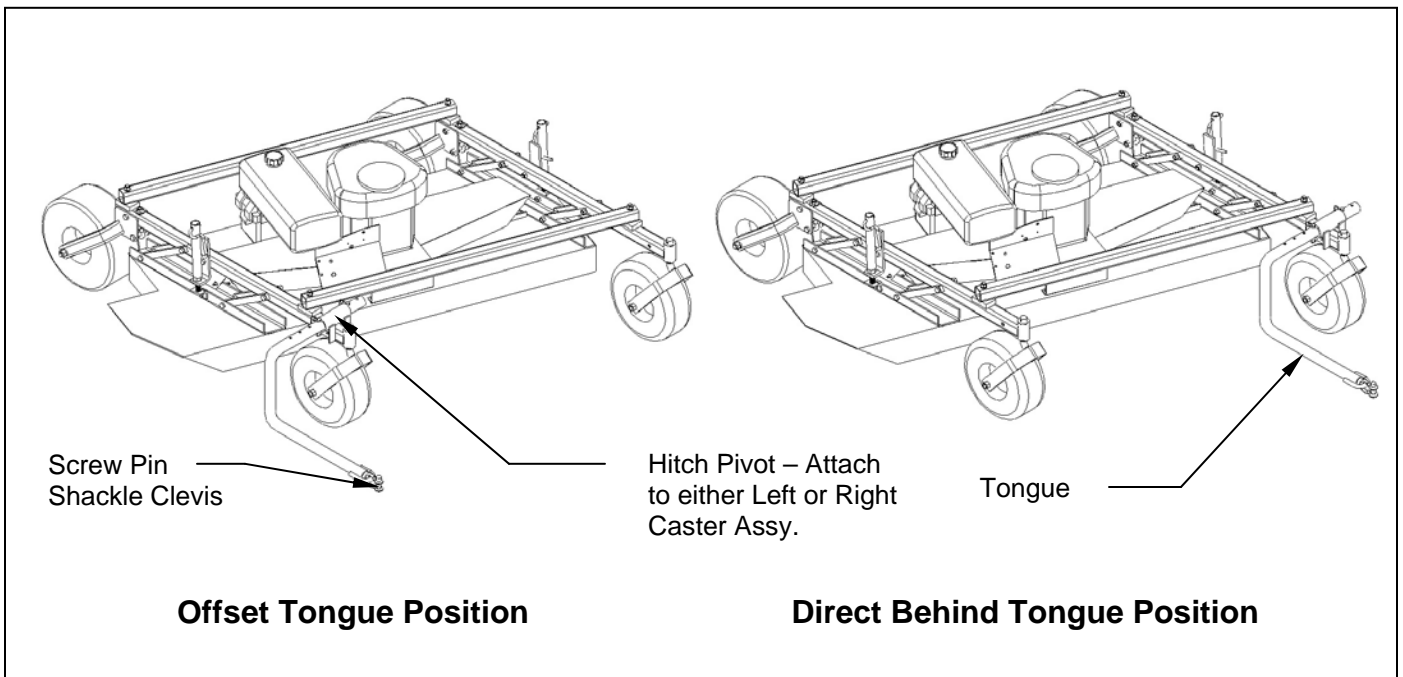

Figure 3. Assembly of Hitch Pivot and ATV Tongue

C. INSTALLATION OF ATV TONGUE ASSEMBLY (if the lawn and garden hitching was purchased refer to Section B. Installation of Lawn & Garden Hitching)

1. The tongue can be installed either on the left or right caster assembly depending on how the wing mower will be towed. **See figure 3.** Secure the hitch pivot on the chosen caster assembly with the 1/2" x 3-1/2" hex head bolt, lock washer, and nut provided.
2. Install the tongue into the hitch pivot and secure by placing a 5/16" wire lock pin on each side of the hitch pivot.

D. INSTALLATION OF OPTIONAL HITCHES

1. When a long tongue is needed, remove the tongue pivot angles and spacer from the tongue assembly and attach to the tongue extension. **See figure 4.** Slip the tongue in between the two flats on the tongue extension and secure with 1/2" x 3-1/2" hex head bolts, lock washers, and nuts provided.
2. When a second mower is pulled behind the first mower in tandem, then the rear hitch assembly can be installed on the rear cross brace tube. **See figure 4.** Remove the four 1/2" x 3-1/2" bolts from the rear hitch assembly and position the rear hitch in the desired location on the cross brace tube. Insert the four 1/2" x 3-1/2" bolts from the bottom up and place the clamping flat on the top. Secure the bolts with the lock washers and the nuts. Tighten down appropriately to prevent unwanted loosening.

Note: The long tongue assembly (Part # 900136) and rear hitch assembly (Part # 900137) must be ordered separately.

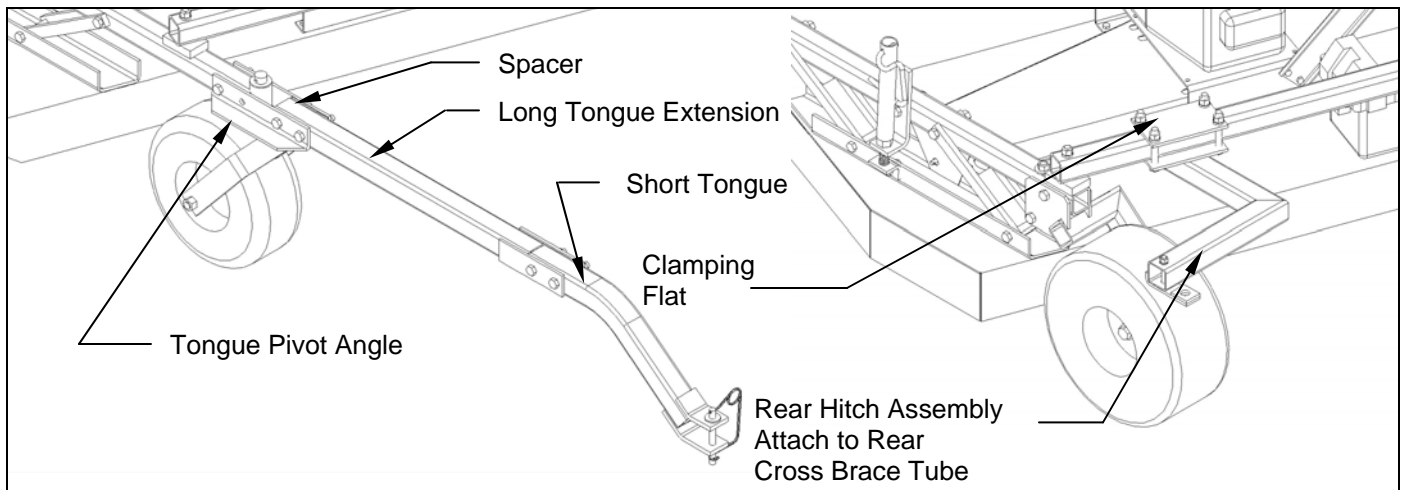

Figure 4: Long Tongue Assembly and Rear Hitch Assembly

OPERATIONS AND ADJUSTMENTS



This safety alert symbol is used to indicate safety instructions. Follow these instructions to avoid personal injury and/or property damage. Read and follow all instructions in this manual and the included engine manual.



WARNING: Do not allow anyone to operate this equipment who has not fully read and comprehended the safety manual and who has not been properly trained in the safe operation of the equipment.



WARNING: Operator should be familiar with all functions of the unit.

A. HITCH CONFIGURATIONS (Refer to Figure 5)



WARNING: Shut off the engine and allow the mower blades to come to a complete stop before adjusting the spreader hitch on the tow vehicle.

Tow Vehicle without a Mower Deck



1 & 2 combined
or 5



1, 2, & 3 combined
or 5



2 & 4
combined

2 & 3
combined

Tow Vehicle with a Mower Deck



1 & 2 combined
or 5



1, 2, & 3
combined

1 & 2
combined

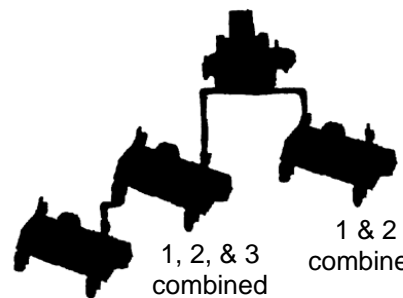

2 & 4
combined

1, 2, & 3
combined

1 & 2
combined

Listed above are all of the possible configurations of the wing mowers. The numbers listed below each wing mower correspond to the hitch or combination of hitches required to complete that possible configuration.

1. Tow Vehicle Hitch (Telescoping Hitch)
2. Short Tongue
3. Long Tongue Extension
4. Rear Hitch Assembly
5. ATV Tongue Assembly

Figure 5: Wing Mower Towing Suggestions and Required Hitches

The hitching system is designed so that the wing mower can be pulled directly behind a tow vehicle without a mower deck or as a left or right wing mower when towed behind a tow vehicle with or without a mower deck.

If more than one wing mower is towed, they can be pulled in tandem or one on the left and one on the right or a combination of the above conditions until the desired cutting width is obtained.



CAUTION: Do not operate two wing mowers in tandem on slopes greater than 25% (1 foot rise, 4 foot run). This can create an unstable condition where the rear wing mower could push the front wing mower sideways.

When mowing large open areas, adjust the spreader hitch on the tow vehicle so that the wing mower tongue center line aligns with the outside cut line on the tow vehicle mower. When trimming around objects or mowing contours, it is best to adjust the tow vehicle hitch in to eliminate skips. The spreader hitch can be adjusted in and out to get the desired overlap to fit your mowing job.

B. ATV TONGUE CONFIGURATIONS (Refer to Figure 5)



WARNING: Shut off the engine and allow the mower blades to come to a complete stop before adjusting the tongue.



WARNING: When attaching the tongue to the back of the tow vehicle, tighten the screw pin shackle clevis firmly. Property damage or bodily injury may occur if the screw pin shackle clevis unturns and the wing mower becomes unattached from the tow vehicle.

The hitching system is designed so that the wing mower can be pulled directly behind a tow vehicle without a mower deck or as a left or right wing mower when towed behind a tow vehicle with or without a mower deck.

Note: When pulling the wing mower directly behind, it is most maneuverable when the hitch pivot is fastened on the left carrier arm. **See Figure 3.** When pulling the wing mower in the offset position, it is most maneuverable to have the hitch pivot fastened on the right carrier arm. **See Figure 3.**

The tongue is designed to adjust from left to right within the hitch pivot. This allows the wing mower and tow vehicle, with a mower deck, to have proper overlap. Overlap is more critical in tight areas where a lot of maneuvering is required. This overlap will eliminate most skips between the tow vehicle and wing mower. In large open areas the overlap is not as critical and should be adjusted to the user's preference.

C. ADJUSTING CUTTING HEIGHT

WARNING: Shut off all engines and allow the mower blades to come to a complete stop on the wing mowers and on the tow vehicle before adjusting the cutting height.

The mower deck must first be leveled from front to back before the height can accurately be adjusted. **See Figure 6.** This is generally a one time adjustment that should not need to be performed again.

Adjust the levelness of the mower deck as follows:

1. Pull the mowing unit on to a smooth, level surface.
2. Start by measuring the front and back deck height directly below the carrier arm on either side. Each side must be adjusted separately.
3. If a difference in measurement is obtained from front to back, the deck needs to be leveled. Turn the level adjustment bolt clockwise to raise the rear end and counterclockwise to lower the rear end.

Note: The rear wheel assy. pivot bolt may need to be slightly loosened to aid in easy adjustment. After levelness has been achieved, the rear wheel assy. pivot bolt must be tightened back up.

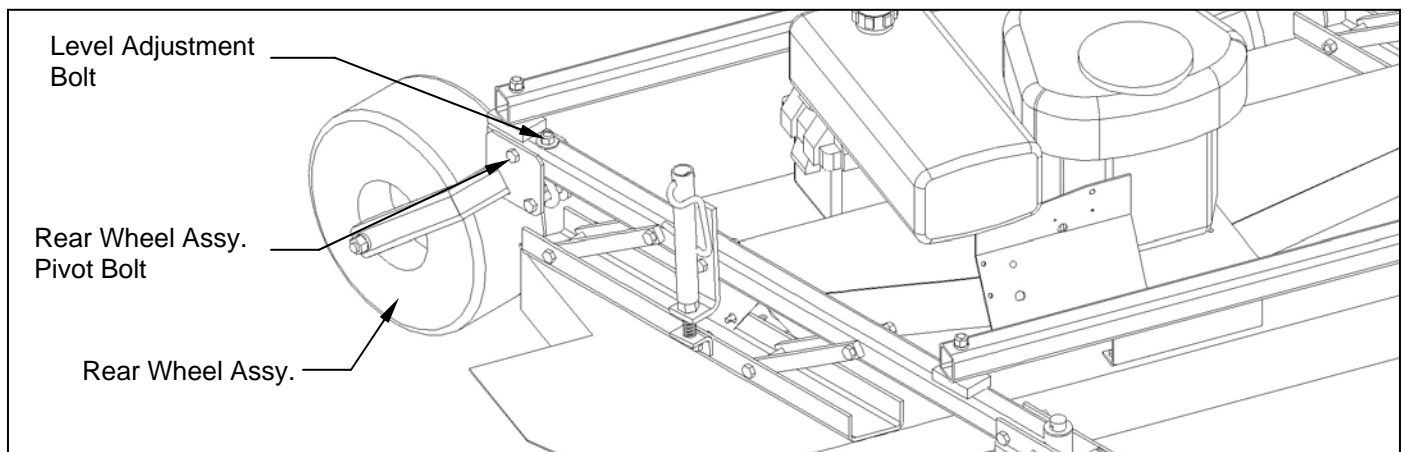

Figure 6: Leveling the Mower Deck

The cutting height can be adjusted in a range from 1.5" to 5.0". This is accomplished by turning the height adjust cranks on both sides of the mower. **See Figure 7.** Turn the cranks clockwise to raise the mower cutting height and counter-clockwise to lower the mower cutting height.

When more than one mower is used at a time, it is very important to have all the mowers adjusted as close to the same cutting height as possible to obtain a high quality cutting job.

DANGER: Shut off tow vehicle engine and allow mower blades to stop completely before attempting to measure the cutting height.

Adjust the mower as follows:

1. Pull the mower on to a smooth, level surface.
2. Adjust the mower evenly from side to side by measuring to the ground from the lower edge of the mower deck. The desired height will be the distance from the ground to the outside lower edge of the mower deck plus $5/16$ ". The mower blade cutting edge is $5/16$ " above the outside lower edge of the mower deck.

Note: If the height adjust cranks do not turn easily, the pivot bolts holding the carrier arm assemblies and height adjust screw may be too tight. Loosen the pivot bolts slightly to allow easier pivoting. Care should be taken not to loosen the pivot bolts too much or excess wear and flexing may occur. Greasing the threads may also allow greater ease in adjustment.

Note: To mow at a 2" cutting height or below, set the anti-scalp wheels in the top hole. To mow above a 2" cutting height, set the anti-scalp wheels in the bottom hole.

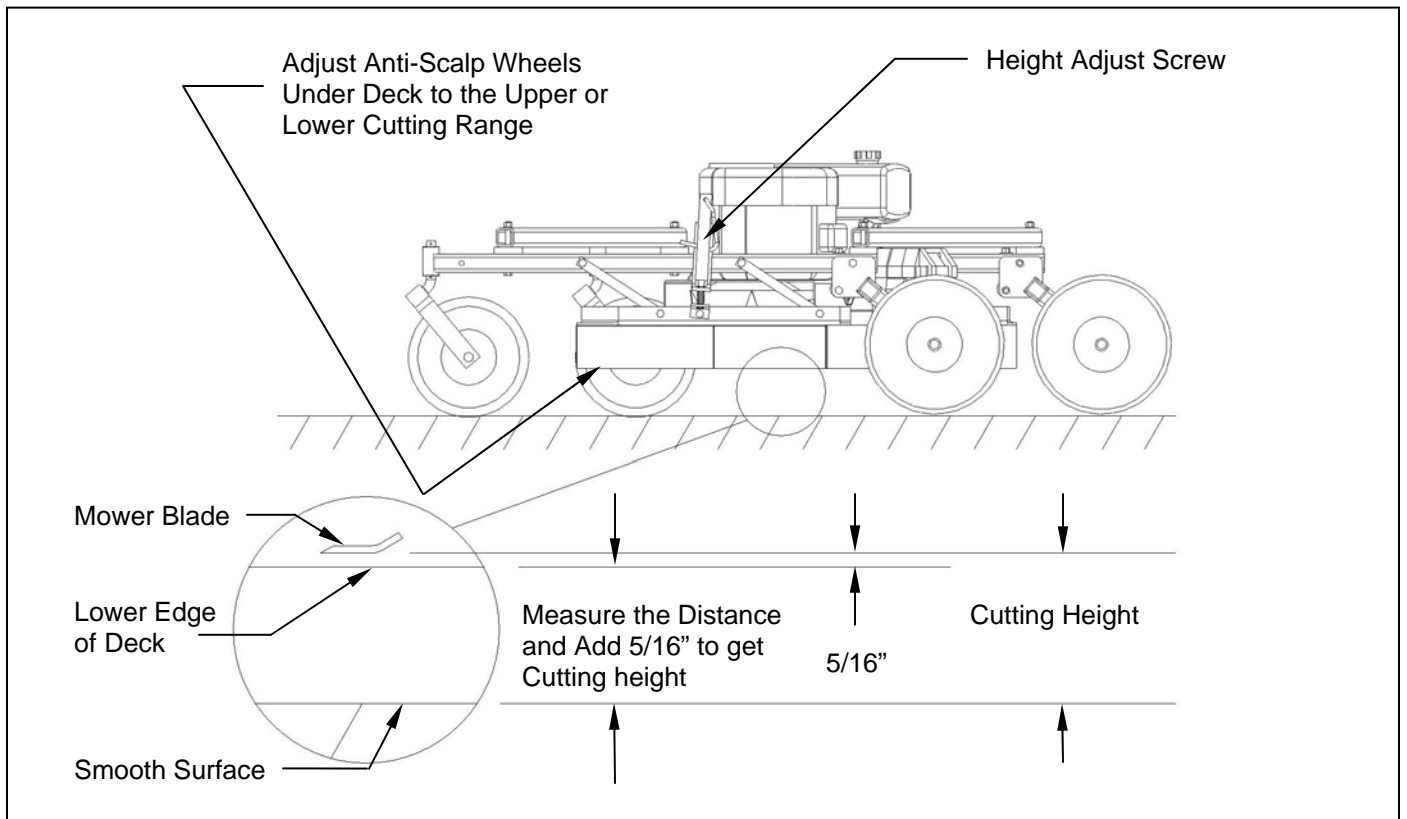

Figure 7: Adjusting Wing Mower Cutting Height

The adjustment crank may unturn due to vibration. This will allow the mower's cutting height to change. The crank can be secured by folding it down between the adjustment nut tube and the upper pivot support. **See Figure 8.**

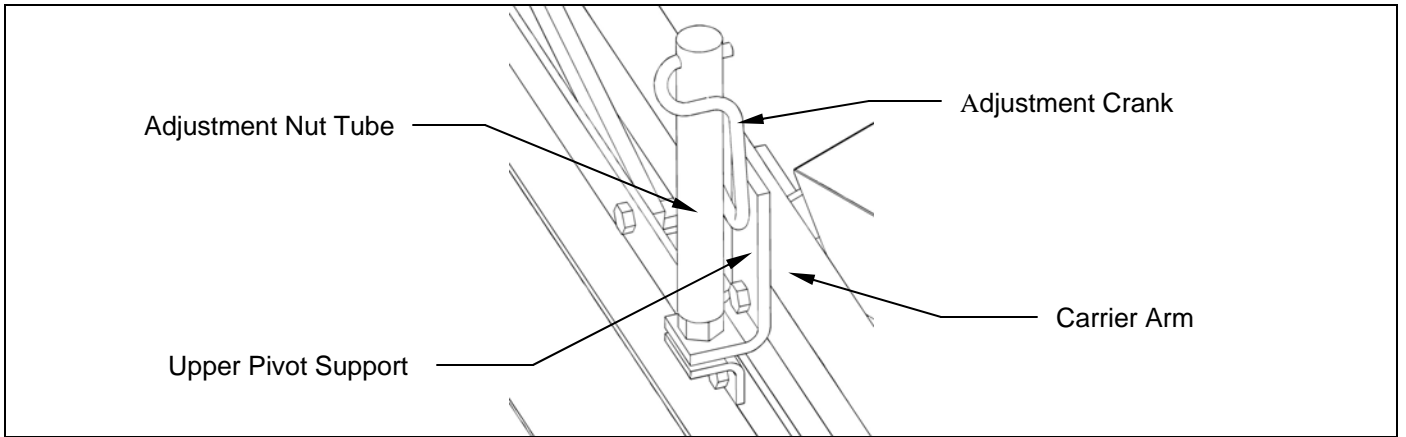

Figure 8: Securing Crank While Not In Use

D. STARTING ENGINE

WARNING: Set parking brake on tow vehicle.

Attach wing mower tongue to tow vehicle.

WARNING: Do not start wing mower unless it is attached to the tow vehicle.

Turn on fuel shut off valve which is located on the underside of the gas tank.

Set the choke to the desired position.

Start engine and allow engine to warm up.

Set the engine speed at about half throttle and engage the mower blades clutch by pulling outward on the PTO switch. (The PTO switch is located at the front of the mower deck on the control panel.)

Note: To help extend the life of the clutch the engine rpm should be placed as low as possible before clutch engagement. If the engine should stall during clutch engagement, raise the engine rpm until clutch engagement is possible.

CAUTION: If the mower's engine dies while in use, remove the wing mower from the uncut area before attempting to engage the clutch. Inspect the blades for any obstructions that may prevent blade engagement. Failure to follow these instructions may result in premature clutch and belt failure or a fire.

Adjust engine speed to full throttle.

CAUTION: The engine full speed setting with mower blades running is 3350 RPM.

E. SHUTTING OFF WING MOWER

 **WARNING:** Shift to neutral, disengage power to the mower deck, and set the parking brake before dismounting the tow vehicle.

Slow the engine speed down and disengage the clutch by pushing inward on the PTO switch.

Allow engine to cool down for a short time before moving the ignition switch to the **off** position.

Turn off fuel shut off valve which is located on the underside of the gas tank.

F. MOWER OPERATION

 **DANGER:** Keep hands, feet, hair and clothing away from moving parts.

 **CAUTION:** Clean or replace any safety signs that are not readable or damaged.

 **WARNING:** Remove all objects from the work area that might be picked up and thrown by the blades.

 **WARNING:** Do not mow when children and others are around.

 **WARNING:** Do not fill fuel tank while engine is running or hot.

 **WARNING:** Keep all safety shields and deflectors in place during operation.

 **CAUTION:** Remove grass build up from under safety shields before each use. Do not remove safety shields while engine is running. Dry grass build up around belts and sheaves can cause fires.

 **WARNING:** Shut off engine before disconnecting the wing mower from the tow vehicle or attempting to move the wing mower by hand.

 **WARNING:** Never carry children or passengers.

 **WARNING:** Do not allow children to operate this machine.

 **CAUTION:** Slow down and watch the ends of the wing mowers when making turns so objects are not struck and/or run over.

Depending on the number of wing mowers being towed, it is usually more efficient to mow the large areas first with the full system. Once the large areas are completed, mowers can be dropped off to mow narrower areas.

Backing up with one wing mower is easy. Backing becomes a greater challenge as additional wing mowers are towed. Avoid backing up by planning ahead. Make loops instead of backing.



WARNING: Look down, to the sides, and behind before and while backing to avoid backing over something or someone. Care should also be taken while backing so that the wing mower or mowers do not jackknife and damage hitches.



WARNING: Stop the mower blades on both the tow vehicle and all wing mowers if the tow vehicle becomes stuck or stops going forward because of loss of traction. Shut off the engines on the wing mowers before attempting to push or pull the tow vehicle.



CAUTION: Do not turn too sharply when the wing mowers are pulled in tandem or pulled behind a zero turn mower. Sharp turns can force the mowers into each other causing damage to the hitches.

Listen to the wing mower engines while mowing. The engines should run free and not work too hard. Working the engine too hard will cause overheating and premature failure.

Do not allow material to build up on the air inlet to the engine cooling system. If the wing mowers are towed with one on the left and one on the right side, there will be a lot of material blowing around the right wing mower engine. Special care should be taken to make sure the engine is getting enough inlet air. Do not allow the engine cooling fins under the shroud to be blocked. Air flow over the engine will be restricted causing the engine to overheat.



CAUTION: If the mower's engine dies while in use, remove the wing mower from the uncut area before attempting to engage the clutch. Inspect the blades for any obstructions that may prevent blade engagement. Failure to follow these instructions may result in premature clutch and belt failure or a fire.

G. DRIVE BELT REMOVAL AND TENSION (See *Figure 9*)



WARNING: Shut off engine and allow mower blades to stop turning before making any adjustments or repairs.

Remove the safety shields.

Loosen the nuts on the spring-loaded idler; adjust the nut until the belt can be slipped off the idler and drive sheaves.

Slip the belt down under the drive sheave and off the blade spindle sheaves.

Install the new belt and adjust the tension as follows:

Adjust the spring-loaded idler springs to a compressed length of 15/16" initially for a few hours until the belt runs in; then adjust the spring to 1-1/8" to 1-1/4" compressed length.

I. LUBRICATION

There are six lubrication points on the wing mower -- one spring-loaded idler pivot, two caster wheel pivots, and three blade spindles. Lubricate at approximately 10 hr. intervals or more often as required in dusty conditions. Lubricate the blade spindles 2-5 pumps every 50 hours. (The bearings have trash guard seals to hold the seals in place during lubrication.) Lubricate with a high grade of pressure gun grease.

Note: Do not over grease blade spindles. Blade spindles are initially greased at the factory. Greasing before 50 hrs. may cause bearing seal damage which will result in premature bearing failure.

J. TIRE PRESSURE

To reduce wing mower bounce on rough yards, the front and rear tire pressure can be reduced so they feel slightly soft (approximately 15 PSI) when they are stepped on.

K. TRANSPORTATION OF MOWER

When transporting the mowers between jobs turn off the fuel shut-off valve. The fuel shut-off valve is located below the fuel tank.

L. STORAGE

Turn off fuel shut off valve which is located on the underside of the gas tank. If the mower is stored outside, the engine should be covered to prevent water from getting inside the engine during heavy rainstorms. See the Engine Manual for additional information.

M. EPA EVAPORATIVE COMPONENTS

This mower has been designed and built to meet all current EPA regulations. Any modification to the fuel tank, fuel lines, vapor hose, fuel cap, roll-over / fuel vapor valve, carbon canister (California Only) and hose clamps are prohibited. Replacement evaporative components should be purchased from Kunz Engineering. Any questions about EPA regulations or evaporative components can be directed to Kunz Engineering Inc. at 815-539-6954.

WING MOWER SPECIFICATIONS

	Model Pro60V
<u>ENGINE:</u>	
Engine Make	Briggs & Stratton Commerical
Engine Model	Vanguard
Cylinders	2
Cycles	4
Crankshaft	Vertical
Engine HP	23
Bore	2.97"
Stroke	2.76"
Displacement	38.26 cu.in.
Oil Capacity	1.5 U.S. qts.
Crankshaft Dia.	1"
Key Slot	1/4"
Crankshaft Length	3.15"
Threaded Hole in End of Crankshaft	7/16-20
Engine Mounting Bolts	5/16-18x1.50 Through Bolt
Starter	Electric
Choke	Manual
<u>MOWER:</u>	
Fuel Tank	3 or 3.75 gal.
Effective Cutting Width	58"
Deck Construction	10 ga. Welded steel
Cutting Height	1.5" to 5"
Height Adjustment	2 Cranks
Anti-Scalp Wheels	4 in front, 2 in rear
(3" O.D. x 1-1/4" wide)	
Rear Wheels (Fixed)	2 15/600 x 6
(4 ply Turf Pnuematic)	
Front Wheels (Caster)	2 13/500 x 6
(Pnuematic Slick)	
Blade Dia.	3-20"
Engine Speed, Blades Running	3350 RPM
CLUTCH TYPE	Electric
Size	200 ft-lb
<u>DIMENSIONS</u>	
Length	65"
Width	72-1/4"
Height	29"
Weight	560 lbs

ACREASE WING MOWER PARTS Pro60V

<u>Item</u>	<u>Part #</u>	<u>Description</u>	<u>Pro60V</u>
1	202136	Blade Bolt, .1/2"-20NF x 1.00"	3
2	204000	Shoulder Bolt, 1/2" x 1-5/8" Shoulder Length	6
3	204015	Eye Bolt (Welded)	2
4	222005	Worm Drive Hose Clamp (7-7/8" to 9-1/8" Clamping Dia.	2
5	222012	Single Split Collar (1" I.D. x .1/2" Thick)	2
6	225000	Compression Spring, 1-1/2"L x 1-3/32" O.D. x .135" Wire dia.	1
7	226000	Plastic Wheel, 3" O.D. x 1/2" I.D. x 1-1/4" Wide	6
8	226003	Offset Wheel Assy., 15/600 x 6, 4 Ply Turf	2
9	226007	Centered Wheel Assy., 13/500 x 6, 4 Ply Slick	2
10	238002	"V" Belt, B Section, 127" O.C. Carlisle/Dayco B124 Super II	1
11	241001	Flat Idler, 4" O.D. x 3/8" Hole	2
12	243007	Precision Sealed Wheel Bearings (1-3/8" O.D. x 5/8" I.D.)	8
13	243010	Plastic Bearing (1-3/8" O.D. x 1.00" I.D., Flange, Nylon)	4
14	258018	Electric Clutch (200 ft-lb, 5" "V" Sheave, 1" Bore)	1
	235062	Clutch Cable Assembly (1)	
15	258020	Spindle Assy.	3
	900046	Spindle Shaft (1)	~
	900139	Housing Assy. (With Two Bearings) (1)	~
	243003	Bearing (2)	~
	600204	Bearing Spacer (3-5/8" Long) (1)	~
	241007	Sheave, 5-1/4" (1)	~
16	259001	Offset Mower Blade, 2" Wide, 20" Long, 1/2" Hole	3
17	260004	Roll-Over / Fuel Vapor Valve (Includes Gromet)	1
18	264000	Solenoid	1
19	264003	Hour/Tack Meter	1
20	264005	PTO Switch	1
21	264006	Fuse Holder (10 Amp Fuse)	1
22	264010	Ignition Switch	1
23	269009	Throttle Control, 27"	
24	269010	Choke Control, 27"	
25	275001	Control Panel Decal, Starting Instructions	1
25	275002	Warning Decal General	1
25	275003	Danger Decal, Cut Finger	2
25	275007	Warning Decal, Belt Sheild	2
25	275019	Name Decal, Kunz	1
25	275021	Name Decal, AcrEase	2
25	275023	Name Decal, 60" Finish Cut	2
26	277002	Rubber Grommet	7
27	277034	Fuel Tank, 3 Gal. EPA Certified	1
28	277035	Gas Cap - Audible Click/Tethered, Non-Venting	1
29	277036	Carbon Canister - 300cc (California Only)	1
30	600048	Solenoid Support	1
31	600062	Belt Sheild L.H.	1
31	600063	Belt Sheild R.H. (Discharge Side)	1
32	600146	Crank Arm	2
33	600198	Clutch Stop	1

<u>Item</u>	<u>Part #</u>	<u>Description</u>	<u>Pro60V</u>
34	600201	Engine Support Bracket	1
35	600212	Upper Pivot Support	2
36	600229	Tube Spacer (Clutch)	1
37	600290	Canister Support (California Only)	1
38	900049	Battery Box Assy.	1
39	900051	Depth Gage	1
40	900052	Tank Support	1
41	900061	Pivot Arm	4
42	900062	Height Adjust Nut	2
43	900066	Screw Adjuster	2
44	900111	Control Panel	1
45	900122	Mower Deck	1
46	900123	Carrier Arm	2
47	900124	Cross Brace Tube	2
48	900125	Rear Wheel Support	2
49	900148	Caster Fork	2
50	900182	Idler Arm Assy.	1
	243000	Bronze Bearing, 1/2" I.D. x 3/4" O.D. x 1-1/2" Long	~

MODELS Pro60V

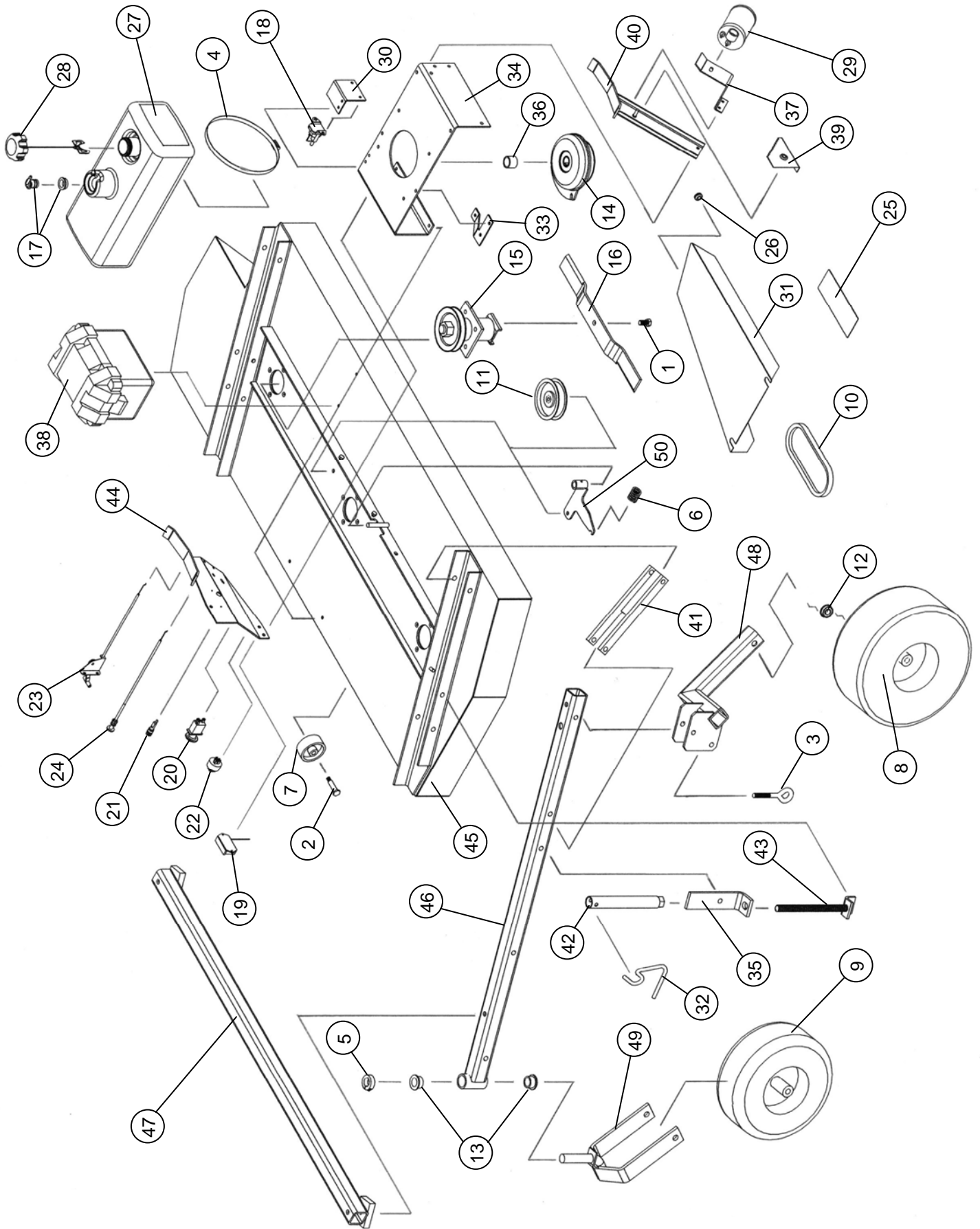

LAWN & GARDEN HITCH PARTS

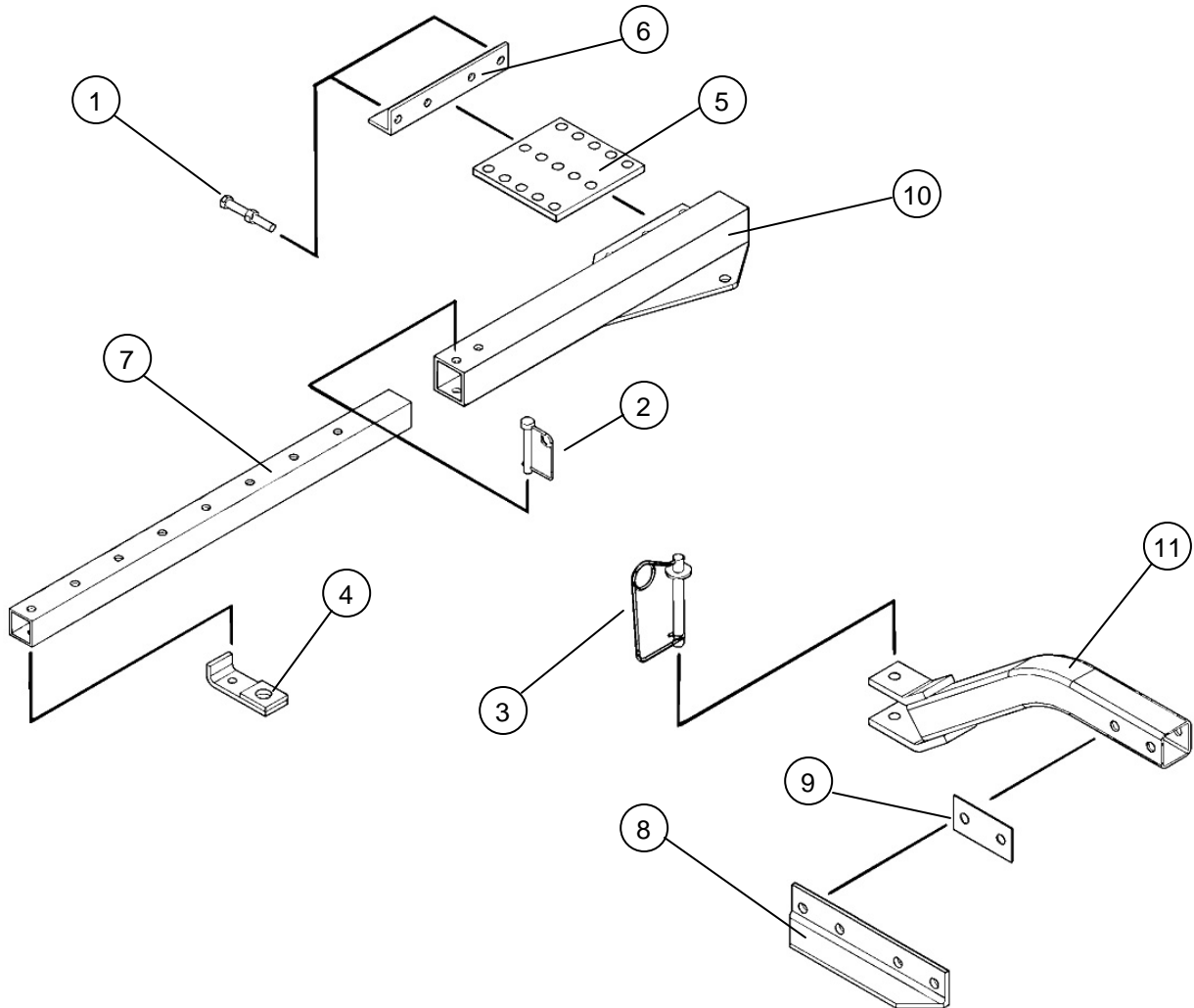

PARTS LIST

<u>Item</u>	<u>Part #</u>	<u>Description</u>	<u>Quantity</u>
1	202135	Hex Head Bolt, 3/8" x 3" Fully Threaded	2
2	216006	Wire Lock Pin, 3/8" x 2-1/4" Opening	1
3	216011	Wire Lock Pin, 1/2" x 3-1/2" Opening	1
4	900050	Hitch Draw Bar	1
5	600044	Hitch Adapter Plate	1
6	600009	Hitch Stop Angle	1
7	600043	Hitch Extension	1
8	600219	Tongue Pivot Angle	2
9	600228	Spacer	1
10	900026	Telescope Hitch	1
11	900130	Short Tongue	1

ATV TONGUE PARTS

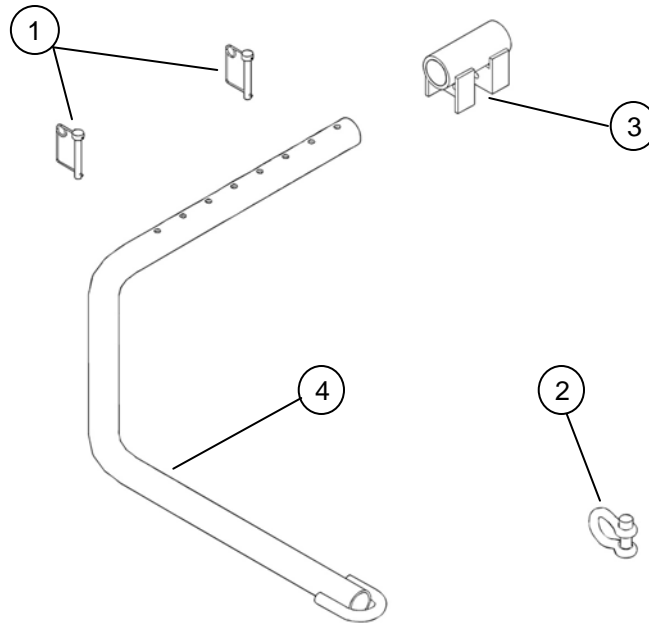

PARTS LIST

<u>Item</u>	<u>Part #</u>	<u>Description</u>	<u>Quantity</u>
1	216002	Wire Lock Pin .31" X 2.50"	2
2	216009	Screw Pin Shackle Clevis	1
3	900058	Hitch Pivot	1
4	900082	Tongue	1

OPTIONAL HITCH PARTS

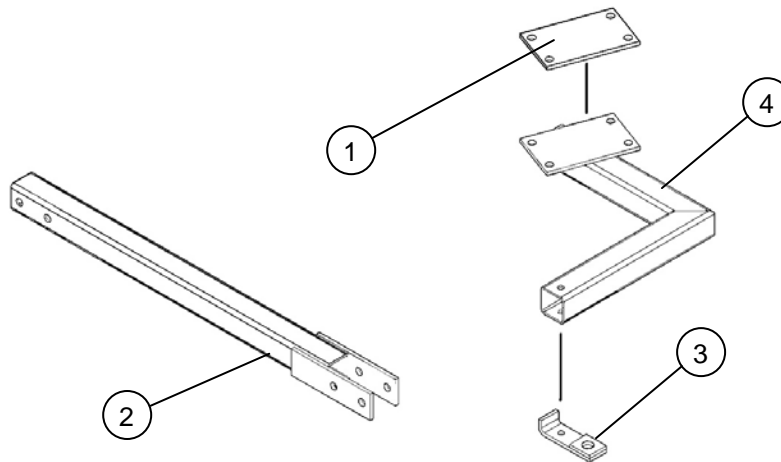

PARTS LIST

<u>Item</u>	<u>Part #</u>	<u>Description</u>	<u>Quantity</u>
1	600195	Clamping Flat	1
2	900131	Long Tongue Extension	1
3	900132	Hitch Draw Bar	1
4	900133	Rear Hitch	1

OPTIONAL EQUIPMENT

OPTIONAL FLOATATION KIT

This optional floatation kit features an extra front and back tire that can be bolted along the center section of the mower deck. This is a great anti-scalp feature that helps to carry the center section of the mower deck and works well in the following applications:

- Rough, uneven ground where added floatation is needed.
- Hard to reach areas at the water's edge around ponds.
- Extending over a creek banks edge.
- Steep road banks where added traction is needed.
- Gradual crowned or peaked areas in a lawn.



The front and rear are sold separately.
Rear Floatation Kit (Part # 003910)
Front Floatation Kit (Part # 003911)