

ACREASE

44" ROUGH CUT



OWNER'S MANUAL

With Assembly Instructions

For Models: MR44B & MR44V

KUNZ ENGINEERING, INC. / MENDOTA, IL 61342 / PH (815) 539-6954



SAFETY INTRODUCTION

Your safety, and the safety of others, is very important. To help you make informed decisions about safety, we have provided operating procedures and other information on labels and in this manual. This information alerts you to potential hazards that could hurt you or others.

You will find important safety information in a variety of forms, including:

Safety Labels – on the mower.

Safety Messages – preceded by a safety alert symbol  and one of three signal words: **DANGER**, **WARNING**, or **CAUTION**.

These signal words mean:



DANGER: Indicates an imminently hazardous situation that, if not avoided, will result in death or serious injury. This signal word is to be limited to the most extreme situations typically for machine components which, for functional purposes, cannot be guarded.



WARNING: Indicates a potentially hazardous situation that, if not avoided, could result in death or serious injury, and includes hazards that are exposed when guards are removed. It may also be used to alert against unsafe practices.



CAUTION: Indicates a potentially hazardous situation that, if not avoided, may result in minor or moderate injury. It may also be used to alert against unsafe practices.

This entire manual is filled with important safety information. Please read it carefully.

IMPORTANT SAFETY INFORMATION



WARNING: Do not allow anyone to operate this equipment who has not fully read and comprehended the safety manual and who has not been properly trained in the safe operation of the equipment.



WARNING: Operator should be familiar with all functions of the unit.



DANGER: Keep hands, feet, hair and clothing away from moving parts.



WARNING: Remove all objects from the work area that might be picked up and thrown by the blades.



WARNING: Do not mow when children and others are around.



WARNING: Keep all safety shields and deflectors in place during operation.



WARNING: Shut off the engine and allow the mower blades to come to a complete stop before making any adjustments to the mower.



WARNING: Shut off engine before disconnecting the mower from the tow vehicle or attempting to move the mower by hand.



WARNING: Never carry children or passengers.



WARNING: Do not allow children to operate this machine.

This entire manual is filled with important safety information. Please read it carefully.

SAFETY SIGNS AND LOCATIONS

WARNING

AVOID INJURY OR DEATH

- Read and follow owner's manual.
- Know location and function of all controls.
- Before starting engine, remove grass build-up from under safety shields.
- Before starting engine, attach machine to tow vehicle.
- Shut off engine before disconnecting machine from tow vehicle or attempting to move machine by hand.
- Do not fill fuel tank while engine is running or hot.
- If tow vehicle stops going forward, stop engine on towed mower before trying to push or pull tow vehicle.
- When making turns, slow down and watch ends of towed mower.
- Never carry children or passengers.
- Look down, to the sides, and behind before and while backing.
- Do not allow children to operate this machine.
- Do not mow when children and others are around.
- Remove all objects that may be thrown by blade.
- Keep safety shields and deflectors in place.
- Shut off engine while in transport.
- Before dismounting tow vehicle: shift to neutral, disengage power to tow vehicle mower, and set parking brake.
- Be sure blades, engine and moving parts are stopped before placing hands or feet near blade or performing service.

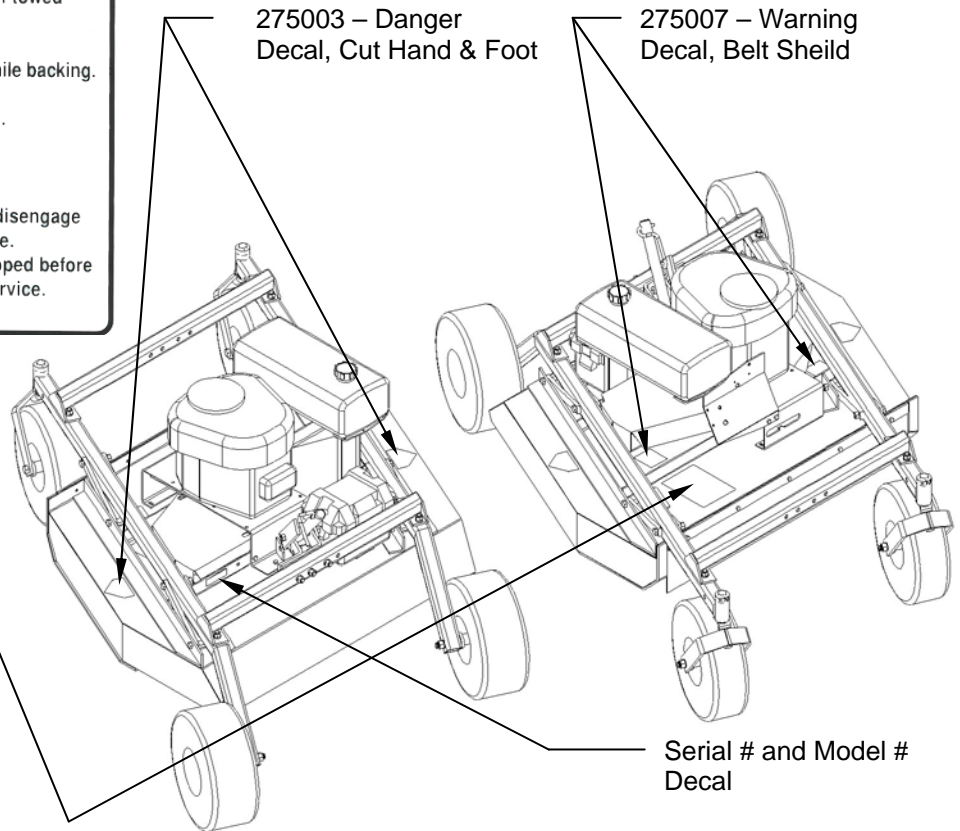

Clean or Replace Any Safety Signs That Are not Readable or Damaged

Replacement decals can be purchased from your local dealer or

Kunz Engineering Inc.
Mendota, IL 61342
(815) 539-6954

ASSEMBLY INSTRUCTIONS

Read the complete assembly instructions before starting the assembly.

You should have:

- one mower deck assembly
- two carrier arm assemblies
- two rear tire assemblies
- one front cross brace tube and one rear cross brace tube with height adjust assy.
- one ATV tongue assembly

A. ASSEMBLY OF REAR WHEELS AND CARRIER ARMS

1. Set the mower deck assembly on wood blocks so that it is suspended off the ground.

Note: The operator controls are on the front of the deck. (Left and right are determined by looking in the direction of travel or by standing at the rear of the deck assembly looking forward.)

2. Install the rear tire assemblies on the carrier arm assemblies. Remove the hex nut and lock washer from the rear tire assembly and install the 5/8"x7-1/2" tire axle bolt through the hole in the carrier arm assembly. **See figure 1.** Secure assembly with the lock washer and hex nut provided on the rear tire assembly. The rear tires should be offset to the outside of the deck assembly on both sides. **See figure 2.**

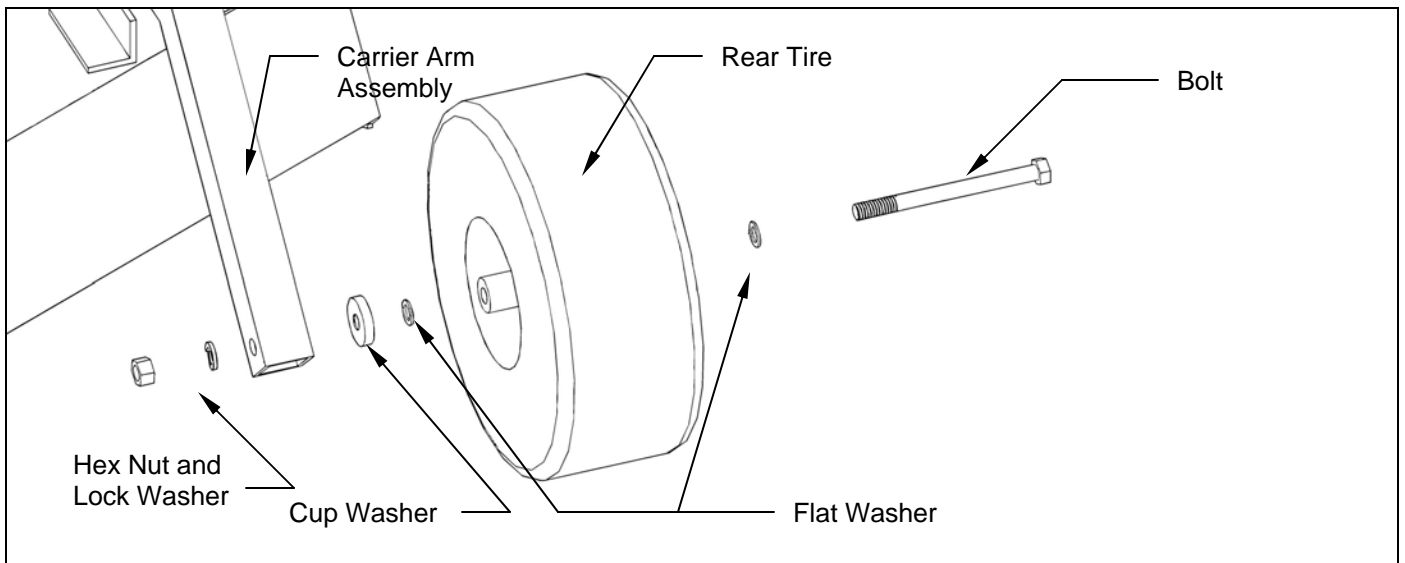

Figure 1: Rear Tire Assembly Installation

3. Install the two carrier arm assemblies in the pivot arms, which are located on the mower deck assembly. Place the assembly so that the castered tires are on the front and the fixed tires are on the back. **See figure 2.** Secure with 1/2" x 3-1/2" hex head bolts and lock nuts provided on the pivot arms.

Note: Tighten 1/2" x 3-1/2" hex head bolts until just snug. This area needs to pivot when adjusting the height. Under tightening can result in excessive wear and flexing. Over tightening will make adjusting the cutting height very difficult.

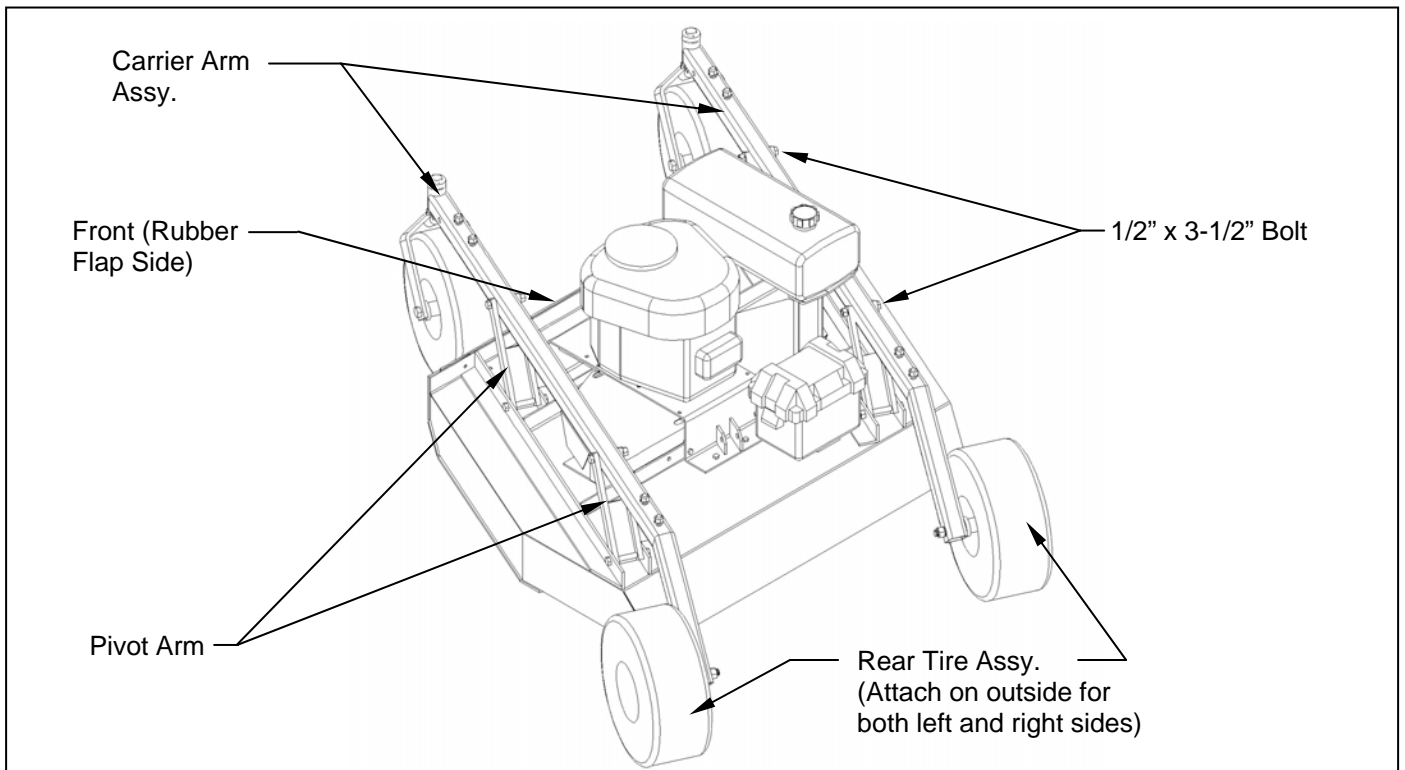

Figure 2: Carrier Arm Installation

B. INSTALLATION OF CROSS BRACE TUBES AND HEIGHT ADJUST ASSY.

For this section, if your mower was purchased with an Electric Lift Kit (Part #003912), refer to Section C of the Electric Lift Kit Owner's Manual.

1. Remove the 1/2" x 3" hex head bolts, lock washers and nuts that are located on the top of each carrier arm (four per carrier arm). The removed hardware will be used in step 2.
2. Install the cross brace tubes on the carrier arms with the 1/2" x 3" hex head bolts, lock washers and nuts. Only hand tighten the hardware for this step. The support that has the height adjust assy. fastened to it needs to be placed on the rear location. Orientate the support such that the height adjust assy. hangs towards the engine. **See figure 3.**
3. Remove the 1/2" x 1" bolt and lock nut from the lower deck mount. Manually turn the screw down towards the deck until the screw mounting flat hole lines up with the lower deck mount hole. After achieving alignment, attach the screw mounting flat with the 1/2" x 1" hex head bolt and secure the bolt with the provided lock nut. Do not over-tighten. This location must be able to pivot. **See figure 4.**

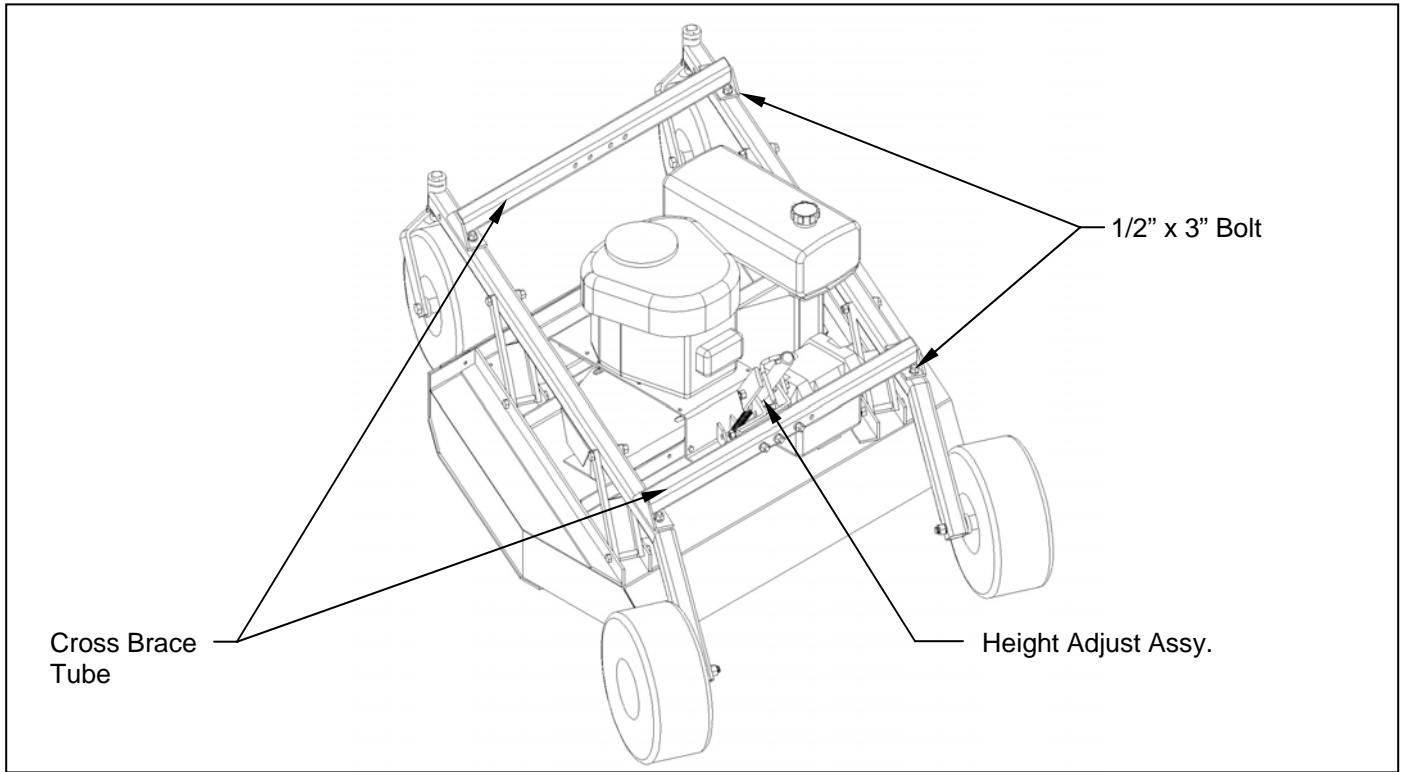

Figure 3: Cross Brace Tube Installation

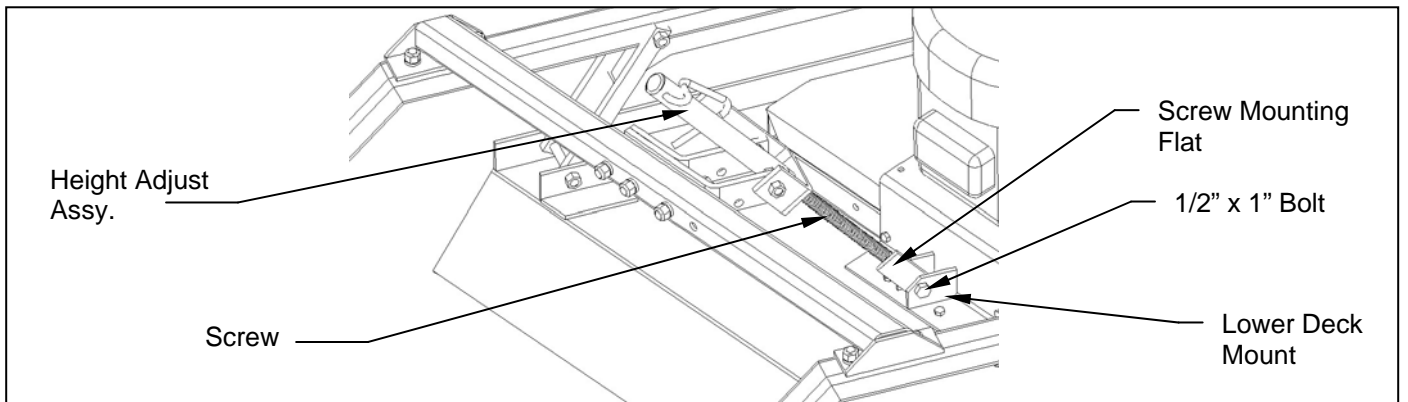

Figure 4: Height Adjust Assy. Installation

4. Turn the crank on the height adjust assy. and raise the mower to its highest position. At this time securely tighten the 1/2" x 3" hex head bolts, lock washers and nuts holding the cross brace tubes in place. This step insures that proper alignment of the carrier arms has been achieved.

C. INSTALLATION OF TONGUE ASSEMBLY

1. The tongue can be installed either on the left or right carrier arm assembly depending on how the tow-behind mower will be towed. **See figure 5.** Secure the hitch pivot on the chosen carrier arm assembly with the 1/2" x 3-1/2" hex head bolt, lock washer, and nut provided.
2. Install the tongue into the hitch pivot and secure by placing the provided 5/16" wire lock pins on each side of the hitch pivot.

Note: To help prevent any unwanted pin removal caused by oncoming debris install the 5/16" wire lock pins with the wire lock section back from the direction of travel. **See Figure 6.**

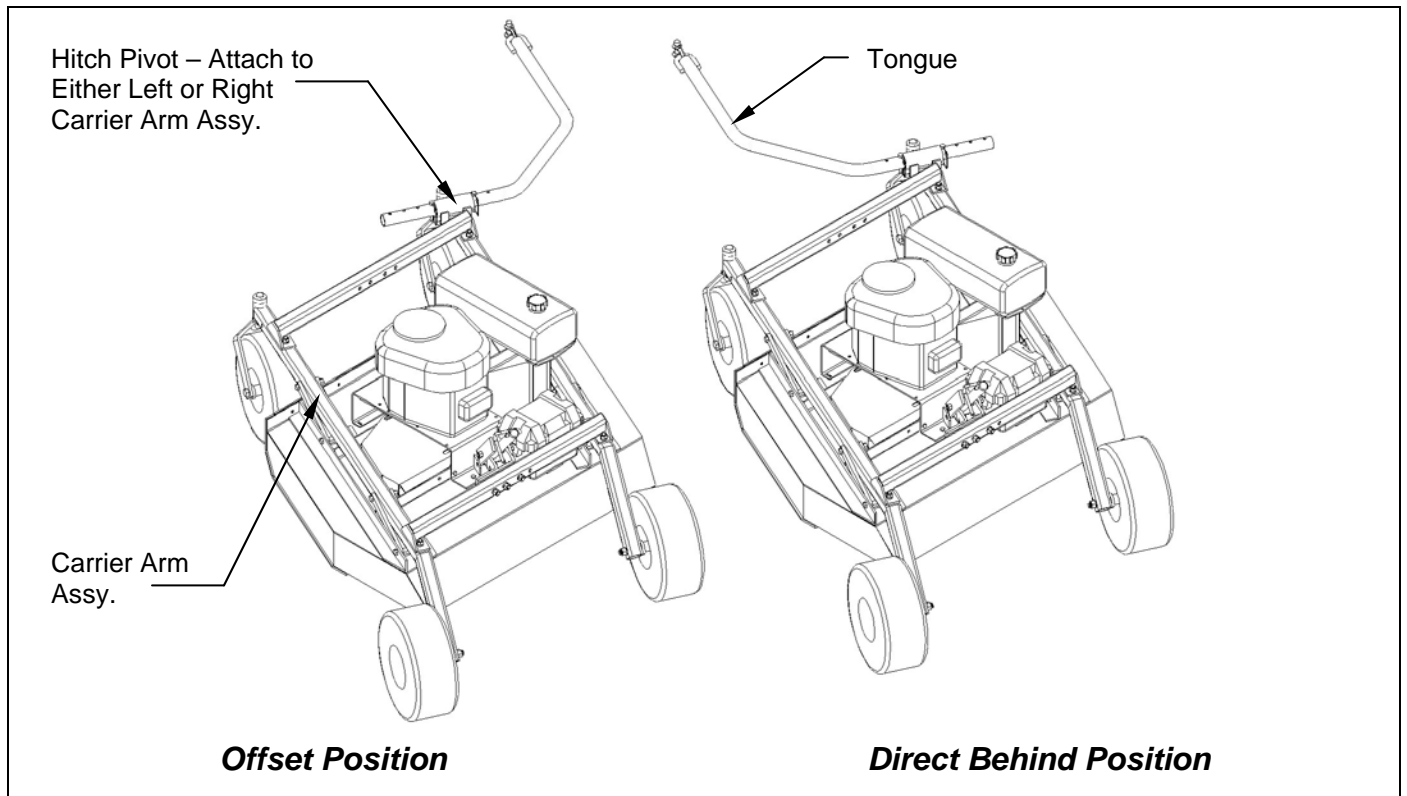

Figure 5: Assembly of the Tongue and Hitch Pivot

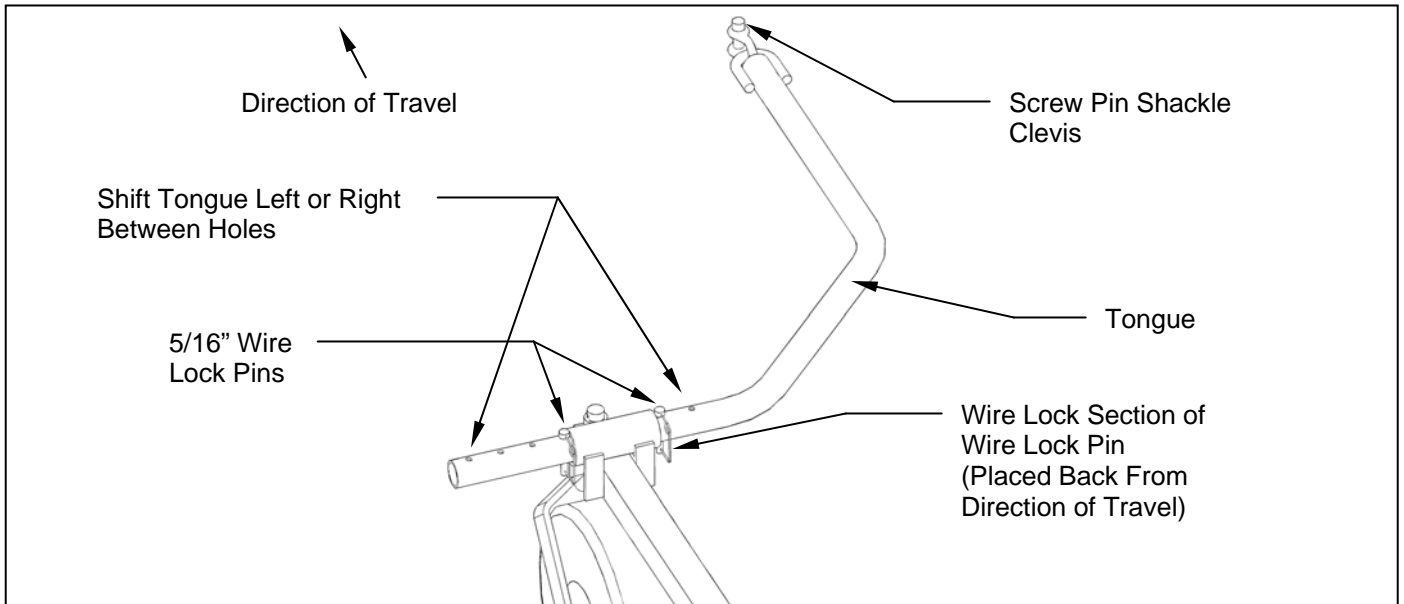

Figure 6: ATV Tongue Assembly

OPERATIONS AND ADJUSTMENTS



This safety alert symbol is used to indicate safety instructions. Follow these instructions to avoid personal injury and/or property damage. Read and follow all instructions in this manual and the attached engine manual.



WARNING: Do not allow anyone to operate this equipment who has not fully read and comprehended the safety manual and who has not been properly trained in the safe operation of the equipment.



WARNING: Operator should be familiar with all functions of the unit.

A. TONGUE CONFIGURATIONS AND ADJUSTMENTS



WARNING: Shut off the engine and allow the mower blades to come to a complete stop before adjusting the tongue.

The hitching system is designed so that the rough cut mower can be pulled directly behind a tow vehicle or offset to the left or right. **See Figure 7.**

Note: When pulling the mower directly behind, the hitch pivot should be fastened on the right carrier arm for maximum maneuverability. **See Figure 5.** When pulling the mower in the offset position the hitch pivot can be fastened on either the right or left carrier arm. **See Figure 5.**

The tongue is equipped with a screw pin shackle clevis to provide movement in all directions on rough uneven ground. To prevent loss of the screw pin due to vibration or debris, place the screw pin through the tow vehicle hitch and clevis and turn the screw pin until snug.

The tongue is designed to adjust from left to right within the hitch pivot. This allows the mowers position to be varied behind the tow vehicle. This is accomplished by pulling the 5/16" wire lock pins out and choosing two other hole locations on the tongue. **See Figure 6.**

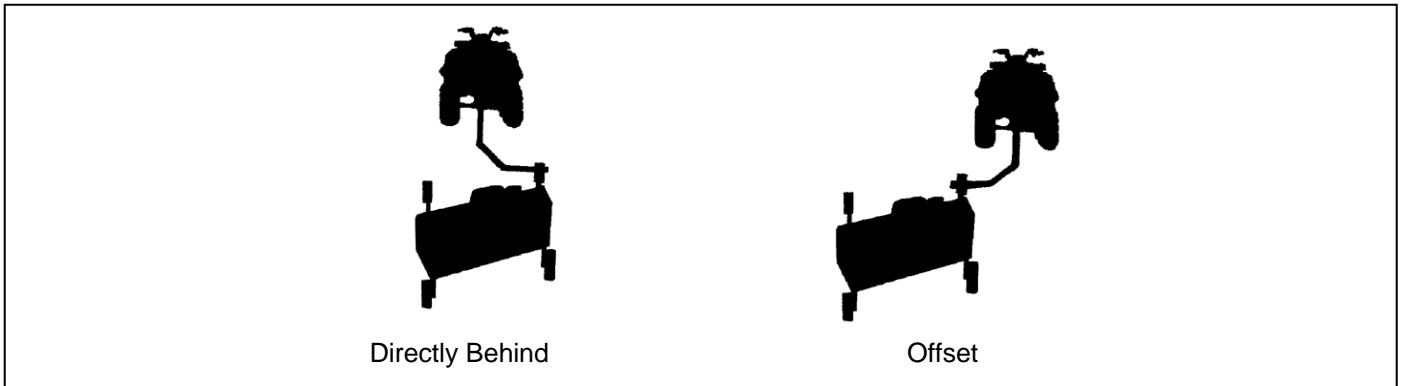

Figure 7: Rough Cut Tow Behind Towing Suggestions

B. ADJUSTING CUTTING HEIGHT



WARNING: Shut off the engine and allow the mower blades to come to a complete stop before adjusting the cutting height.

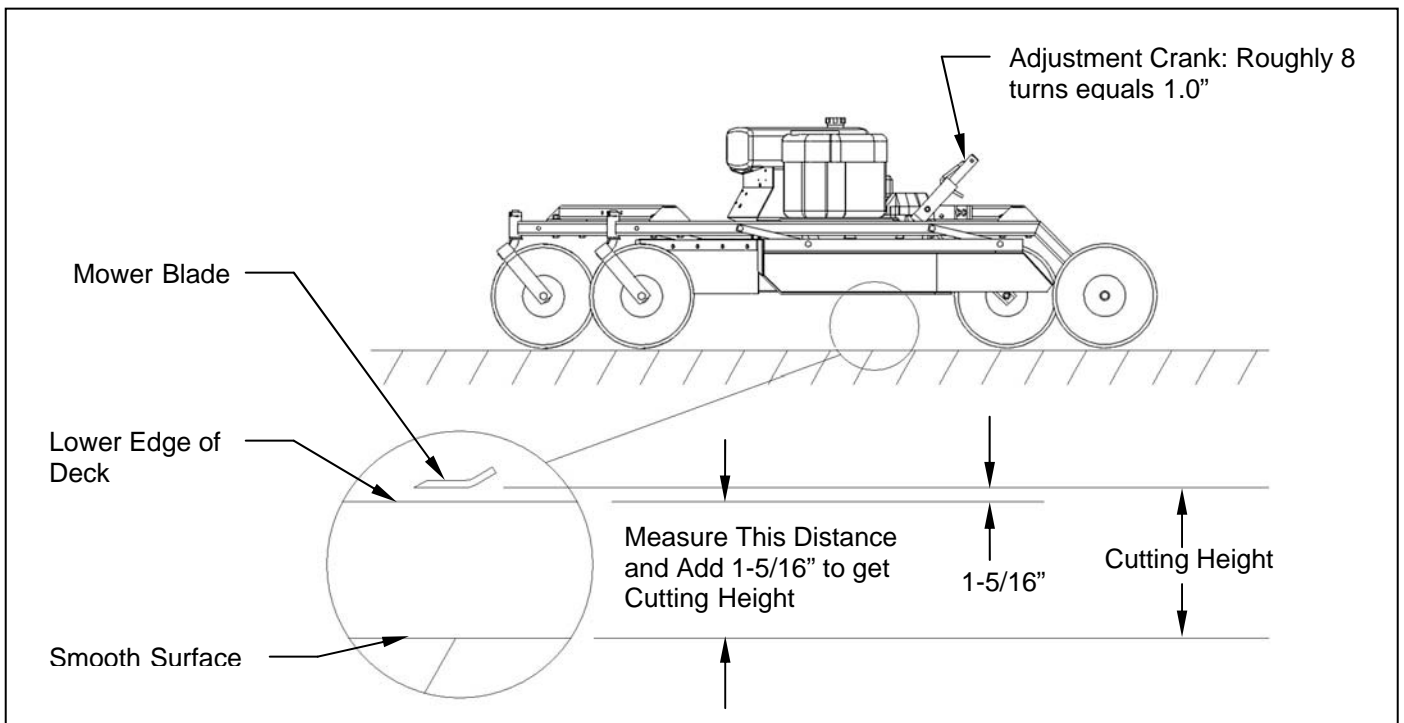

Figure 8: Adjusting Rough Cut Mower Cutting Height

The cutting height can be adjusted in a range from 2.0" to 8.0". This is accomplished by turning the height adjust crank located at the back of the mower. **See Figure 8.** Turn the crank clockwise to raise the mower cutting height and counter-clockwise to lower the mower cutting height.

⚠ DANGER: Shut off tow vehicle engine and allow mower blades to stop completely before attempting to measure the cutting height.

Adjust the mower as follows:

1. Pull the mower on to a smooth, level surface.
2. The desired cutting height can be determined by measuring the distance from the ground to the outside lower edge of the mower deck and adding 1-5/16". The mower blade cutting edge is 1-5/16" above the outside lower edge of the mower deck.

Note: If the height adjust crank does not turn easily, the pivot bolts holding the carrier arm assemblies and height adjust screw may be too tight. Loosen the pivot bolts slightly to allow easier pivoting. Care should be taken not to loosen too much or excess wear and flexing may occur. Greasing the threads on the height adjust screw may also allow greater ease in adjustment.

Note: After setting the initial cutting height, quick field adjustments can be completed by counting crank turns. Roughly 8 turns will equal 1" of vertical movement.

The adjustment crank may unturn due to vibration. This will allow the mower's cutting height to change. The crank can be secured by folding it down between the adjustment nut tube and the height adjust support. **See Figure 9.**

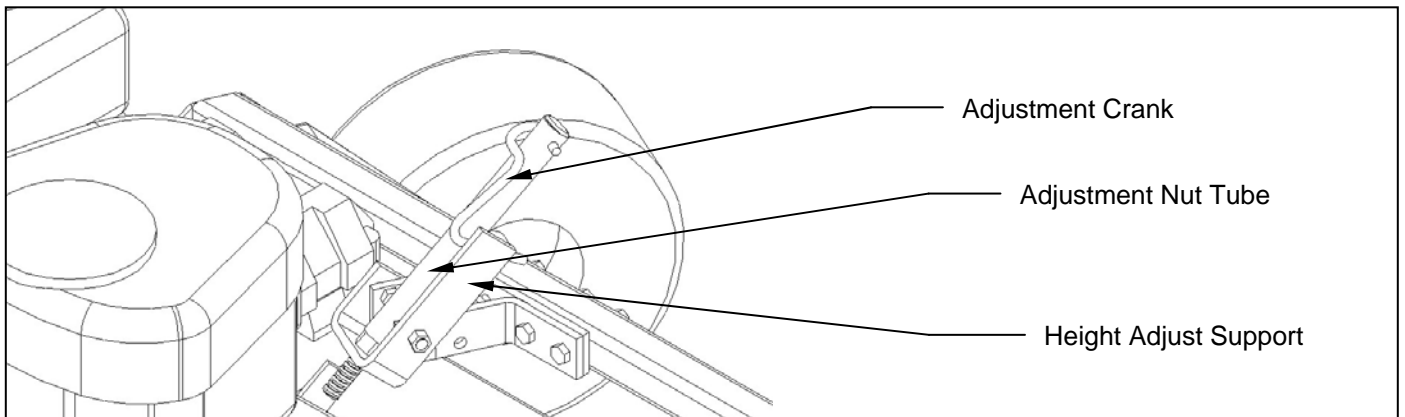

Figure 9: Securing Crank While Not In Use

C. STARTING ENGINE



WARNING: Set parking brake on tow vehicle.

Attach mower tongue to tow vehicle.



WARNING: Do not start rough cut mower unless it is attached to the tow vehicle.

Turn on fuel shut off valve which is located on the underside of the gas tank.

Set the choke to the desired position.

Set the throttle at approximately half throttle.

Start engine and allow engine to warm up.

Set engine speed at about half throttle and **slowly** engage mower blades clutch handle. (The clutch handle is located at the front of the mower under the engine.)

Note: Some belt squealing may occur on engagement. This is normal for a manual clutch engagement design.



CAUTION: If the mower's engine dies while in use, remove the rough cut mower from the uncut area before attempting to engage the clutch. Inspect the blades for any obstructions that may prevent blade engagement. Failure to follow these instructions may result in premature belt failure or a fire.

Adjust engine speed to full throttle.

D. SHUTTING OFF ROUGH CUT MOWER



WARNING: Shift to neutral and set the parking brake before dismounting the tow vehicle.

Slow the engine speed down to an idle and **slowly** disengage the clutch handle.

Allow engine to cool down for a short time before moving the ignition switch to the **off** position.

Turn off fuel shut off valve which is located on the underside of the gas tank.

E. MOWER OPERATION



DANGER: Keep hands, feet, hair and clothing away from moving parts.



CAUTION: Clean or replace any safety signs that are not readable or damaged.



WARNING: Remove all objects from the work area that might be picked up and thrown by the blades.



WARNING: Do not mow when children and others are around.



WARNING: Do not fill fuel tank while engine is running or hot.



WARNING: Keep all safety shields and deflectors in place during operation.



CAUTION: Remove grass build up from under safety shields before each use. Do not remove safety shields while engine is running. Dry grass build up around belts and sheaves can cause fires.



WARNING: Shut off engine before disconnecting the mower from the tow vehicle or attempting to move the wing mower by hand.



WARNING: Never carry children or passengers.



WARNING: Do not allow children to operate this machine.



CAUTION: Slow down and watch the ends of the mower when making turns so objects are not struck and/or run over.



WARNING: Look down, to the sides, and behind before and while backing to avoid backing over something or someone. Care should also be taken while backing so that the wing mower or mowers do not jackknife and damage hitches.



WARNING: Stop the mower blades on the mower if the tow vehicle becomes stuck or stops going forward because of loss of traction. Shut off the engine on the mower before attempting to push or pull the tow vehicle.

Listen to the rough cut mower engine while mowing. The engine should run free and not work too hard. Working the engine too hard will cause overheating and premature failure.



CAUTION: If the mower's engine dies while in use, remove the rough cut mower from the uncut area before attempting to engage the clutch. Inspect the blades for any obstructions that may prevent blade engagement. Failure to follow these instructions may result in premature belt failure or a fire.

Do not allow material to build up on the air inlet to the engine cooling system. Special care should be taken to make sure the engine is getting enough inlet air. Do not allow the engine cooling fins under the shroud to be blocked. If air flow over the engine is restricted, the engine could overheat.

F. DRIVE BELT REMOVAL AND TENSION – Refer to Figure 10



WARNING: Shut off engine and allow mower blades to stop turning before making any adjustments or repairs.

Remove the safety shields.

Loosen the nuts on the spring-loaded idler; adjust bolt until the belt can be slipped off the idler and drive sheaves.

Slip the belt down under the drive sheave and off the blade spindle sheaves.

Install the new belt and then adjust the tension as follows: **See Figure 10.** Take special care to make sure that the belt is placed between the brake stud and the idler pulley.

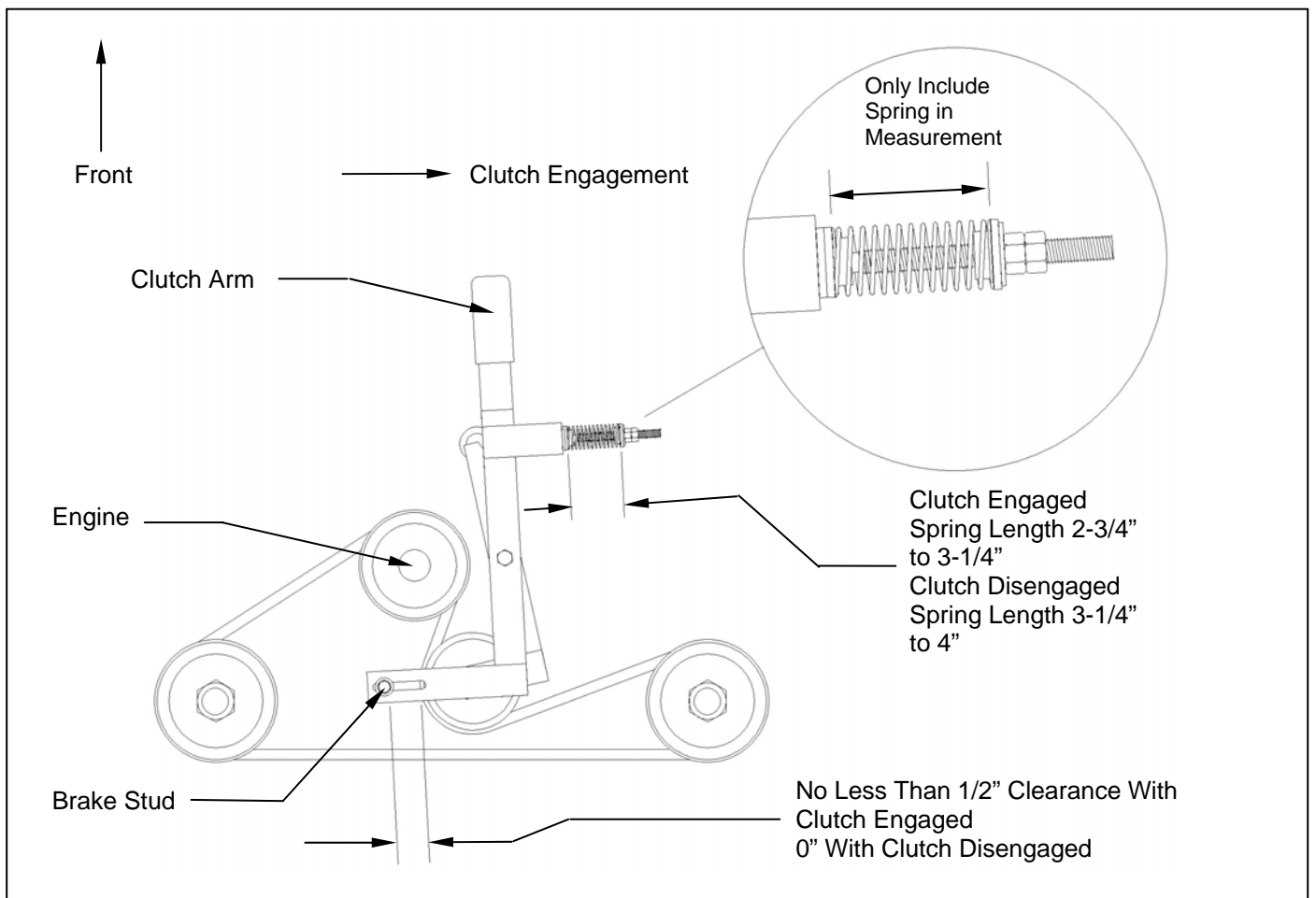

Figure 10: Belt Pattern, Spring Adjustment, and Brake Adjustment

With the clutch engaged, adjust the nuts on the spring-loaded idler adjuster bolt until the length of the spring is approximately 2-3/4". This is the initial belt break in spring length. When the belt is broken in after several hours of mowing, the running spring length should be between 2-3/4" and 3-1/4". For maximum belt life, periodic checks every 3-4 hours should be done to make sure the spring length has not exceeded the recommended running length.

Note: Failure to periodically adjust the belt tension will result in severe belt wear and premature belt failure.

This model comes with a belt brake, which is a safety feature that stops the blades from turning after the clutch is disengaged. The only time the brake should be in contact with the belt is when the clutch is disengaged.



CAUTION: The brake stud may need to be adjusted if there is significant belt wear or if a different size belt is used. If the brake stud is not adjusted correctly, the blades will still spin even though the clutch may be in the disengaged position. Always shut mower engine off before servicing.

Under normal operating conditions and when using the Kunz Engineering belt (Part # 238007) the brake stud should require very little adjustment. Periodic brake stud inspections should be performed every 10 hours. In more severe cutting conditions, more frequent inspections may be necessary. There are two parts to inspecting the brake stud. Those two inspections are the disengaged spring length and brake stud clearance.

Note: It is quicker to perform the disengaged spring length and brake stud clearance inspections if done simultaneously.

Disengaged Spring Length:

This inspection must be performed to make sure that there is proper braking force to prevent the blades from spinning when the clutch is in the disengaged position. With the clutch in the disengaged position measure the spring length. The spring must be between 3-1/4" and 4" to provide the appropriate braking force. If the spring length is over 4" it will be necessary to adjust the brake stud closer to the belt. If the spring length is less than 3-1/4" it will be necessary to adjust the brake stud further away from the belt. To make brake stud adjustments loosen the bolt on the top of the brake stud and slide the brake stud in the slot. When the proper disengaged spring length is achieved, tighten the bolt on the top of the brake stud. For this procedure do not adjust the spring length. The spring length should only be changed when adjusting the belt tension.

Brake Stud Clearance:

This inspection is necessary to prevent over-braking. To inspect the brake stud clearance it is easiest to remove the left belt shield and observe from the left side. With the clutch engaged, check to make sure that there is at least 1/2" of clearance between the brake stud and the belt. If the clearance is less than 1/2" then it will be necessary to adjust the brake stud away from the belt. Keep in mind that the disengaged spring length must stay between 3-1/4" and 4".

Note: If the brake stud is adjusted to the end of the slot and the brake stud clearance is under 1/2" then it is time to replace the belt.



CAUTION: If brake stud is not set in correct position, under-braking or over-braking may occur. If over-braking occurs, premature belt failure or a possible fire could occur due to excessive friction and overheating.

G. MOWER BLADE REMOVAL, BALANCING & INSTALLATION



CAUTION: Sharp blades can cause bodily injury if not handled properly.

When removing the blade, it is recommended that a block of wood be placed between the blade and the underside of the mower deck. This will allow the removal of the blade without the need to hold the blade by hand.



CAUTION: Always balance the mower blades each time they are sharpened.

Out of balance mower blades cause excessive vibrations which lead to premature bearing failures, bolts coming loose, and overall deterioration of the mower.



CAUTION: Always properly tighten the blade bolts to the specified torque. Failure to do so can lead to unwanted loosening of the blade and damage to the blade holding saddle.

The Models MR44B and MR44V use the Kunz Engineering Part # (202141) blade bolt. This particular hex head bolt is a 3/4" – 16NF x 1-1/4" long, grade 5 and its proper torque is 300 ft-lbs.

To ease in the blade installation process, use the same block of wood and method used during the removal of the blades.

H. LUBRICATION

There are three lubrication points on the rough cut mower -- one spring-loaded idler pivot and two caster wheel pivots. Lubricate at approximately 10 hr. intervals or more often as required in dusty conditions.

I. STORAGE

Turn off fuel shut off valve which is located on the underside of the gas tank. If the mower is stored outside, the engine should be covered to prevent water from getting inside the engine during heavy rainstorms. See the Engine Manual for additional information.

J. EPA EVAPORATIVE COMPONENTS

This mower has been designed and built to meet all current EPA regulations. Any modification to the fuel tank, fuel lines, vapor hose, fuel cap, roll-over / fuel vapor valve, carbon canister (California Only) and hose clamps are prohibited. Replacement evaporative components should be purchased from Kunz Engineering. Any questions about EPA regulations or evaporative components can be directed to Kunz Engineering Inc. at 815-539-6954.

ACREASE ROUGH CUT MOWER SPECIFICATIONS

	Model <u>MR44B</u>	Model <u>MR44V</u>
<u>ENGINE:</u>		
Engine Make	Briggs & Stratton	Briggs & Stratton Commercial
Engine Model	Intek AVS OHV	Vanguard
Cylinders	1	2
Cycles	4	4
Crankshaft	Vertical	Vertical
Engine HP	19.5	18
Bore	3.57"	2.84"
Stroke	3.06"	2.76"
Displacement	30.6 cubic inches	34.78 cubic inches
Oil Capacity	1.5 U.S. qt	1.5 U.S. qt
Crankshaft Dia.	1.0"	1.0"
Key Slot	1/4"	1/4"
Crankshaft Length	3.15"	3.15"
Threaded Hole in End of Crankshaft	7/16-20	7/16-20
Engine Mounting Bolts	5/16-18x1.50 Through Bolt	5/16-18x1.50 Through Bolt
Starter	Electric	Electric
Choke	Manual	Manual
<u>MOWER:</u>		
Fuel Tank	3 or 3-3/4 Gal.	3 or 3-3/4 Gal.
Effective Cutting Width	44"	44"
Deck Construction	8 ga. Welded steel	8 ga. Welded steel
Cutting Height	2" to 8"	2" to 8"
Height Adjustment	Single Crank	Single Crank
Rear Wheels (Fixed) (4 ply Turf Pnuematic)	Two 15/600 x 6	Two 15/600 x 6
Front Wheels (Caster) (4 ply Turf Pnuematic)	Two 5.30/4.50 x 6	Two 5.30/4.50 x 6
Blade Dia.	2-23"	2-23"
Engine Speed, Blades Running	3500 RPM	3500 RPM
<u>CLUTCH TYPE</u>		
Engagement Speed	Manual	Manual
<u>DIMENSIONS</u>		
Length	95.5"	95.5"
Width	46.5"	46.5"
Height	29"	29"
Weight	520 lbs.	530 lbs.
<u>HITCH</u>		
Hitch Type	ATV Tongue	ATV Tongue
<u>TOUCH-UP PAINT COLOR</u>		
	Pewter Gray, Krylon #1606	Pewter Gray, Krylon #1606

ACREASE ROUGH CUT MOWER PARTS LIST

<u>Item</u>	<u>Part #</u>	<u>Description</u>	<u>Quantity</u>
1	202141	Blade Bolt, .75"-16UNF x 1.25"	2
2	214021	Cup Washer	6
3	216002	Wire Lock Pin, .31" x 2.50"	2
4	216009	Screw Pin Shackle Clevis	1
5	222005	Worm Drive Hose Clamp (7-7/8" to 9-1/8" Clamping Dia.)	2
6	222012	Single Split Collar (1" I.D. x 1/2" Thick)	2
7	225005	Compression Spring, 4-1/2"L x 1-3/32" O.D. x .125" Wire dia.	1
8	226003	Offset Wheel Assy. (15/600 x 6, 4 Ply Turf)	2
9	226004	Centered Wheel Assy. (5.30/4.50 x 6, 4 Ply Stud)	2
10	238007	"V" Belt, .62" x 77" O.C. (B74K)	1
11	241001	Flat Idler, 4" O.D. x 3/8" Hole	1
12	241010	"V" Sheave, 5" Dia. 1" Bore	1
13	243007	Precision Sealed Wheel Bearings (1-3/8" O.D. x 5/8" I.D.)	8
14	243010	Plastic Bearing (1-3/8" O.D. x 1.00" I.D., Flange, Nylon)	4
15	258023	Spindle Assy.	2
	900075	Spindle Shaft (1)	
	900160	Housing Assy. (With Two Bearings) (1)	
	243006	Bearing (6206 w/ Trash Guard Seals) (2)	
	600271	Bearing Spacer (3.33" Long) (1)	
	241011	Sheave, (5.56" Dia., B-Section) (1)	
16	259008	Offset Mower Blade, 2-1/2" Wide, 23" Long, 3/4" Hole	2
17	260004	Roll-Over / Fuel Vapor Valve (Includes Gromet)	1
18	264000	Solenoid	1
19	264010	Ignition Switch	1
20	264003	Hour/Tack Meter	Optional
21	269000	Choke Control, 20" (MR44B)	1
21	269010	Choke Control, 27" (MR44V)	1
22	269001	Throttle Control, 15" (MR44B)	1
22	269009	Throttle Control, 27" (MR44V)	1
23	275001	Control Panel Decal, Starting Instructions	1
23	275002	Warning Decal General	1
23	275003	Danger Decal, Cut Finger	2
23	275007	Warning Decal, Belt Shield	2
23	275011	Clutch Engagement Decal	1
23	275019	Name Decal, Kunz	1
23	275021	Name Decal, AcrEase	1
23	275024	Name Decal, 44" Rough Cut	1
24	277002	Rubber Gromet	6
25	277011	Handle Grip	1
26	277034	Fuel Tank, 3 Gal. EPA Certified	1
27	277035	Gas Cap - Audible Click/Tethered, Non-Venting	1
28	277036	Carbon Canister - 300cc (California Only)	1
29	600071	Spacer, 1.38" O.D. x 1.33" Wall x 2.19" Long	1
30	600136	Brake Stud	1
31	600146	Crank Arm	2

<u>Item</u>	<u>Part #</u>	<u>Description</u>	<u>Quantity</u>
32	600185	Top Long Support	1
33	600186	Top Short Support	1
34	600252	Flap Retainer Strip	1
35	600253	Safety Belting	1
36	600254	Battery Box Spacer	2
37	600264	Belt Sheild, Left	1
38	600265	Belt Sheild, Right	1
39	600268	Height Adjust Support	1
40	600291	Canister Support (California Only)	1
41	600292	Clutch Arm	1
42	900023	Control Panel	1
43	900049	Battery Box Assy.	1
44	900058	Hitch Pivot	1
45	900061	Pivot Arm	4
46	900079	Tank Support	1
47	900082	Tongue	1
48	900148	Caster Fork	1
49	900150	Engine Support Bracket	1
50	900154	Upper Actuator Mount	2
51	900155	Carrier Arm	2
52	900156	Mower Deck	1
53	900157	Height Adjust Nut	1
54	900158	Screw Adjuster	1
55	900180	Idler Arm Assy.	1
	243005	Bronze Bearing, 1/2" I.D. x 3/4" O.D. x 3/4" Long	2

ACREASE 44" ROUGH CUT MOWER PARTS

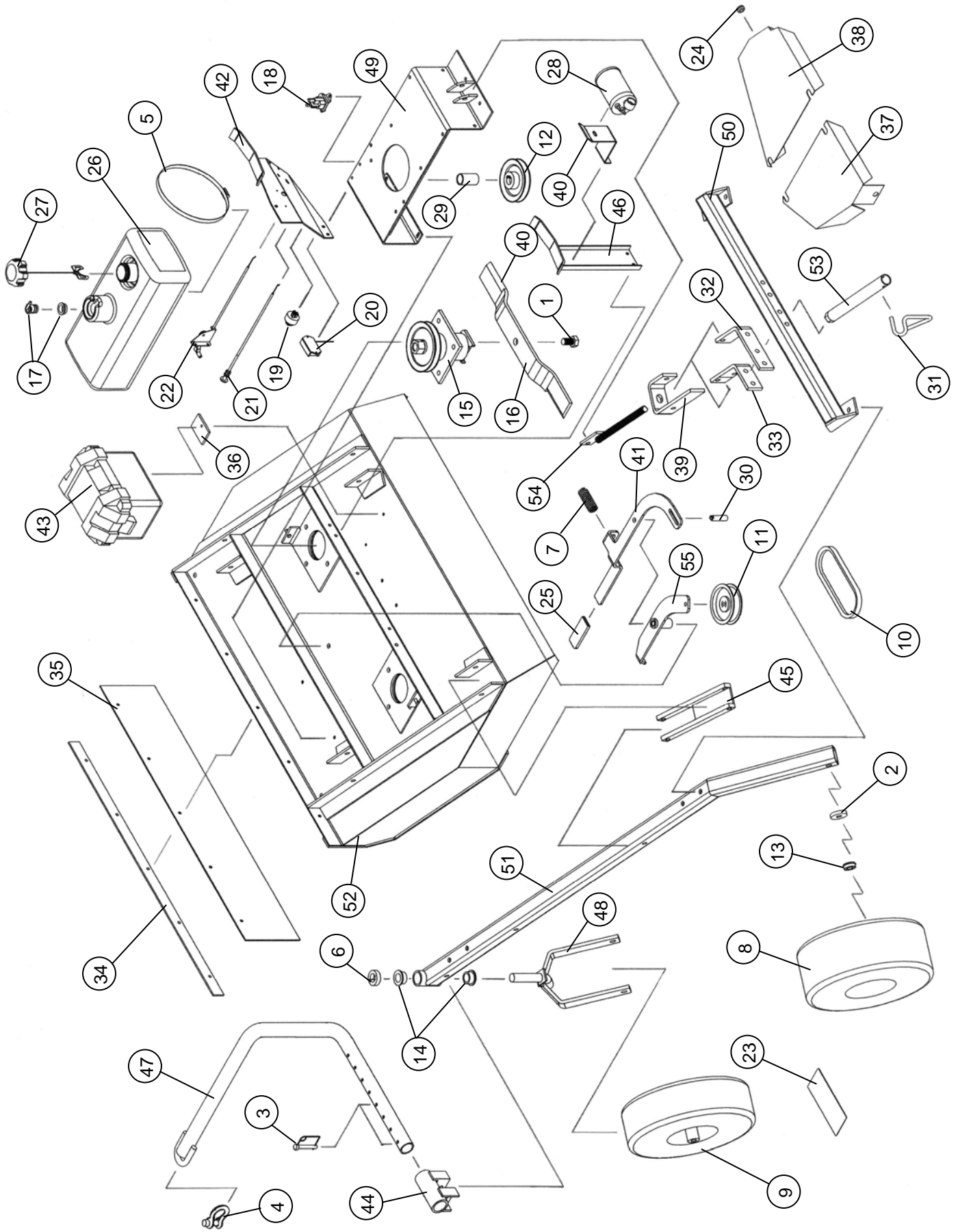

OPTIONAL EQUIPMENT

OPTIONAL WETLANDS KIT

The optional wetlands kit features an extra set of tires for added ground support in soft or water saturated areas. The following are applications and features that the wetlands kit works best in.

- Great for wetlands or marshy areas that stay wet all year around.
- Works well in combination with small personal amphibious vehicles or tracked ATVs.
- More than doubles the tire surface area in contact with the ground.
- Very easy to install bolt-on kit.
- Works on all existing and new rough cut mowers.
- The rough cut mower **will not** float with the wetlands kit installed. Water greater than 2-3" in depth should be avoided.
- With the Wetlands Kit installed, the minimum cutting height is 3.5" – 4".



Shown on the 57" Rough Cut Mower

Wetlands Kit (Part # 003905)

OPTIONAL EQUIPMENT

OPTIONAL ELECTRIC LIFT KIT

The optional electric lift kit consists of all of the mounting hardware, brackets, electric actuator and wiring with remote control panel.

- Great for constantly changing terrain and grass/brush heights.
- Allows for quick cutting height changes on the go from the seat of the tow vehicle.
- Raise up and over rocks and logs with ease.
- Heavy duty 1500 lb linear screw actuator made by Linak.
- Works on all existing and new rough cut mowers.



Shown on the 57" Rough Cut Mower

Electric Lift Kit (Part # 003912)

OPTIONAL EQUIPMENT

OPTIONAL FLOATATION KIT

The optional floatation kit consists of one additional front and rear tire, mounting brackets and hardware.

- Great for mowing around ponds and on rough uneven ground where scalping would normally occur.
- Clamping style receiver allows for adjustments from side to side with both the front and rear tires.
- Pinned receivers make for quick kit removal when not needed.
- Works on all existing and new rough cut mowers.



Shown on the 57" Rough Cut Mower

Rear Floatation Kit (Part # 003907)

Front Floatation Kit (Part # 003908)